

IDEAL 5560



Table of Contents

Safety precautions	3
Intended use	4
Installation	8
Startup	9
Operation	12
Operating elements	16
Blade and cutting stick replacement	24
Maintenance and cleaning	35
Annual inspection / Safety test	37
Possible malfunctions	38
Accessories	42
Technical data	43
EC-declaration of conformity	46

Safety precautions



Please read these operating instructions before putting the machine into operation and observe the safety precautions.
The operating instructions must always be available.



Children must not operate the machine!



Do not reach beneath the blade!



Never leave the blade unattended!
Do not extract or transport the blade without protection! (See page 27 and 29).
⚠ Danger! Risk of injury!

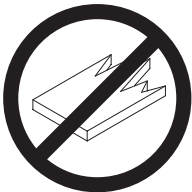

Do not cut hard materials or materials which may splinter!

Safety precautions / Intended use



Do not use any spray cans with flammable content near to the cutting machine!



Do not use any flammable cleaning agents.

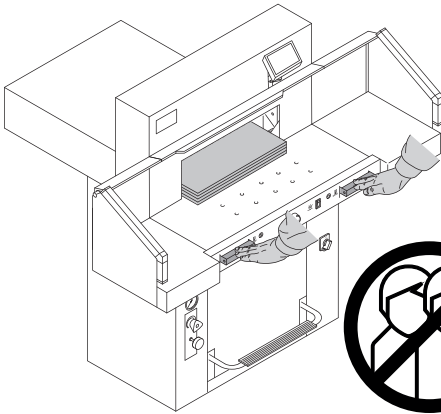

Intended use

The machine is designed for cutting stacks of paper to a specified size.

This machine is constructed for "one-man operation" only!

⚠ Warning! Clips or similar damage the cutting blade.



Safety precautions

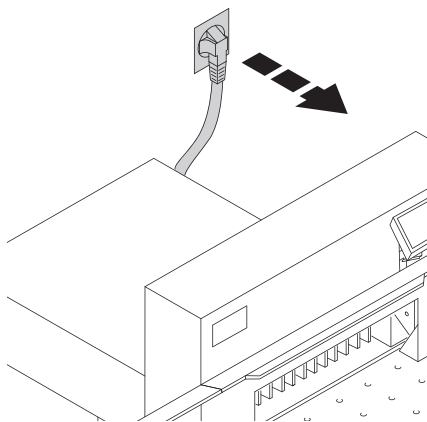

Disconnect from the mains before starting any service work or before removing the panels!

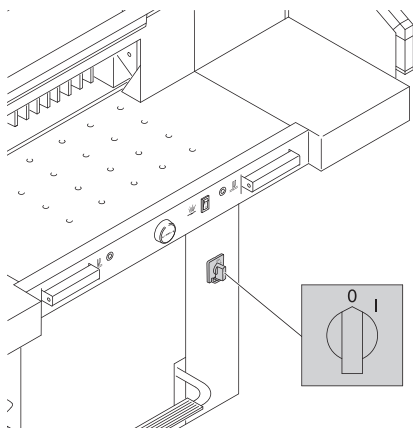

Replacement of blade and cutting stick may be performed only when the main switch is switched off!

Safety precautions

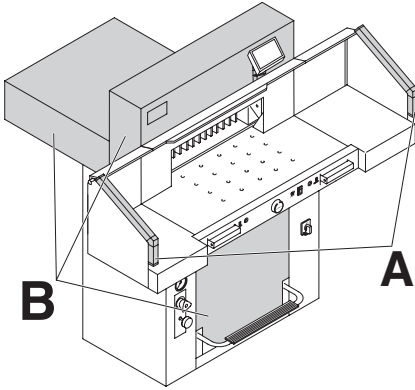

All components which could endanger the operator are covered by a guard (**B**)!

Do not operate the machine without the following safety devices:

- Safety beam guard (**A**)
- Panels, tightly screwed (**B**).

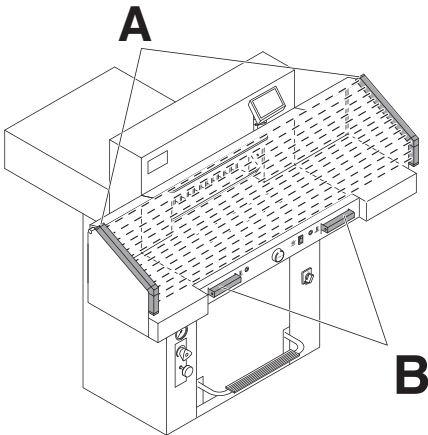

The cutting action, which is dangerous to the operator, is protected by a two-handed control system (**B**) and safety beam guard (**A**).

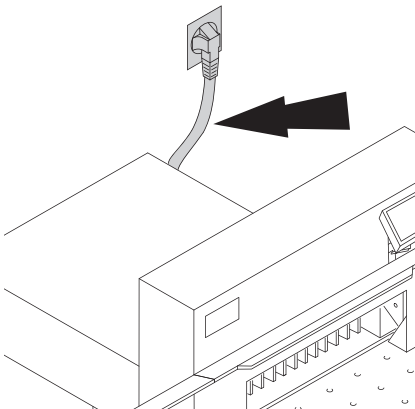

Protect mains cable against heat, oil and sharp edges!

Standard machines are factory-set as follows:

- Voltage 230 V (120 V) 1 phase
- Frequency 50 Hz (60 Hz).

Safety precautions

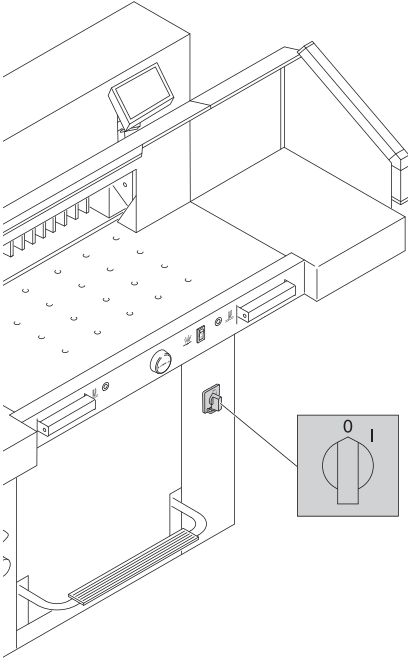

When not in use for a longer period switch off. (Main switch to "0").

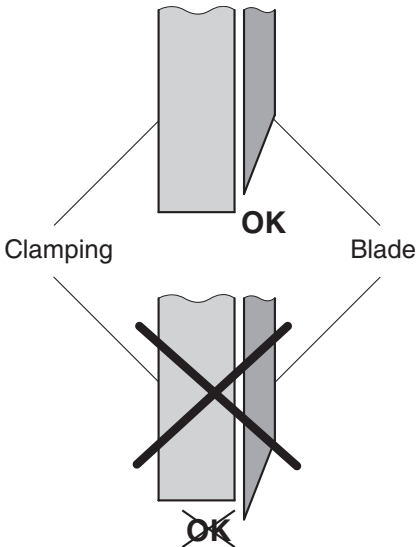

⚠ Danger!
Blade must always be covered by the pressing bar.

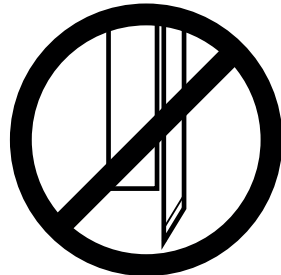

Installation

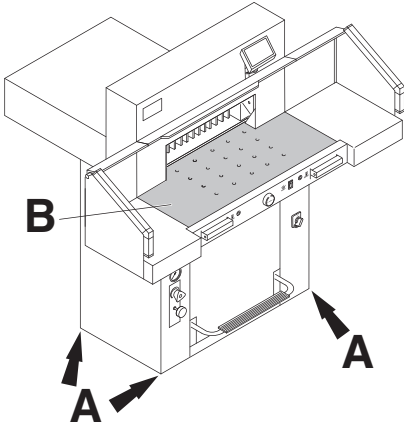

The machine is mobile on castors. Align the machine as follows:

- Align machine with water level and adjust accordingly.
4 x screws size 19 (A).
- Reference area machine table (B).

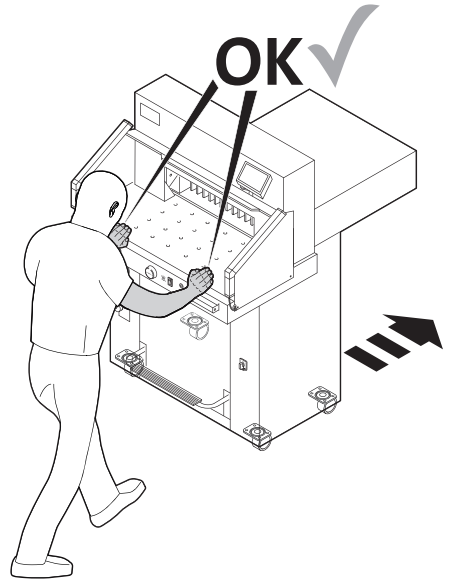
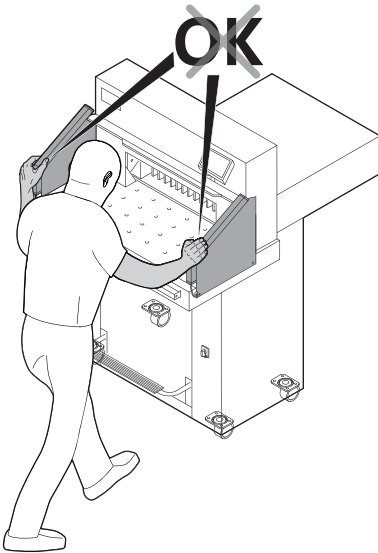

Installation / Startup

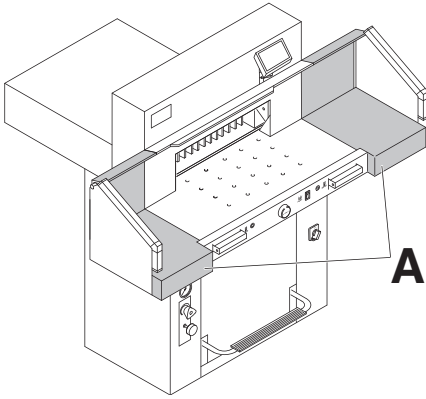

The machine is delivered ready for operation. Side tables (A), left and right are available as an option. Assembly instructions are included.

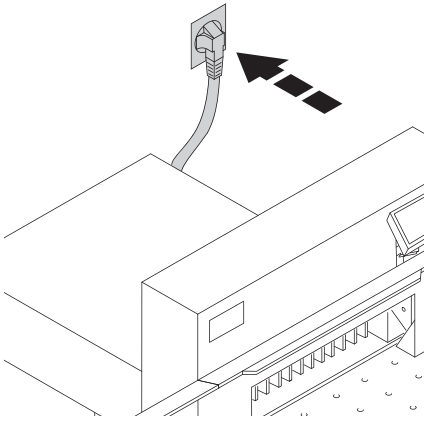

Startup

Plug into socket.

Startup

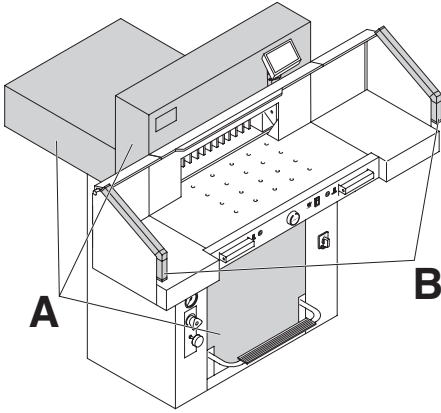

The machine may only be operated, if the operating instructions and the safety instructions have been understood. Before each use, check the safety equipment for completeness and functionality.

- All covers have to be mounted (A).
- Safety beam guard must be mounted (B).
- The release for cutting is allowed only if the two-hand safety device is operated at the same time (C)
- **Safety light beam:**
If the test rod (E, tool kit) is held into the protective field (D), an activated work cycle must be stopped immediately.

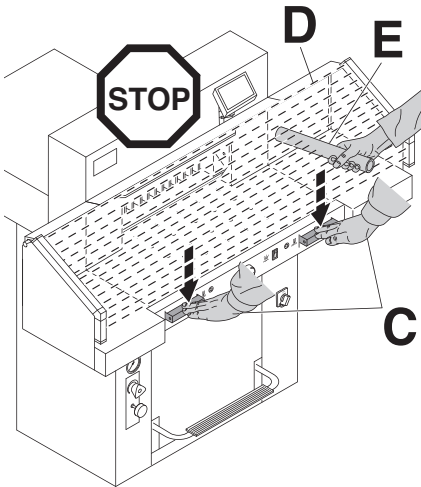

We recommend you keep a record of your test results.

Startup

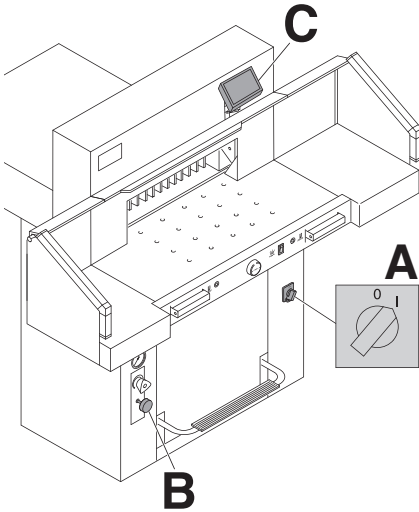

Display (C) is pivotable. By loosening the allen head screw (D), (allen wrench is in the tool box) the display can be pivoted within the elongated hole. Tighten allen screw again.

Position the main switch to "I" (A).
Blade locking facility (B) must be pulled out.
Press  (C). → Machine will automatically go to the start position.
The machine is now ready for use.

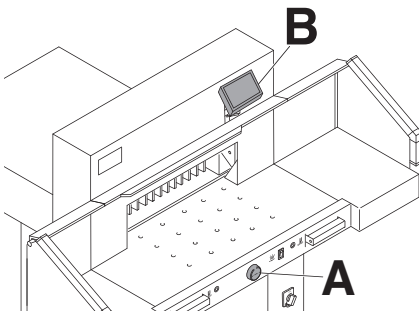
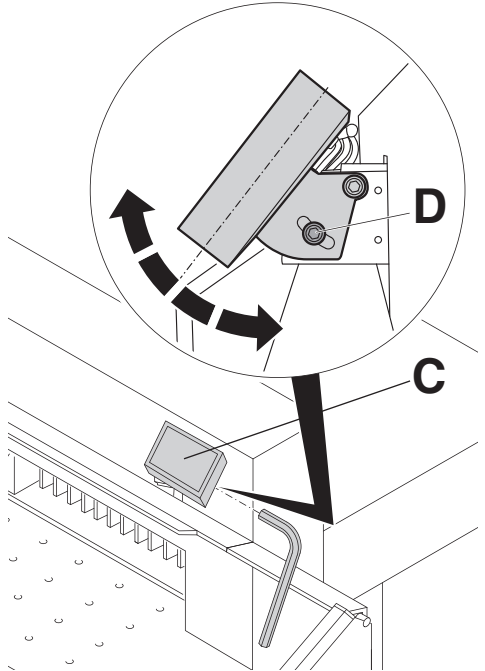

The measurement is set either with the handwheel (A) or by programming (B) the cutting measurements. Measurement is shown on the display in inches or cm (B).

Operation

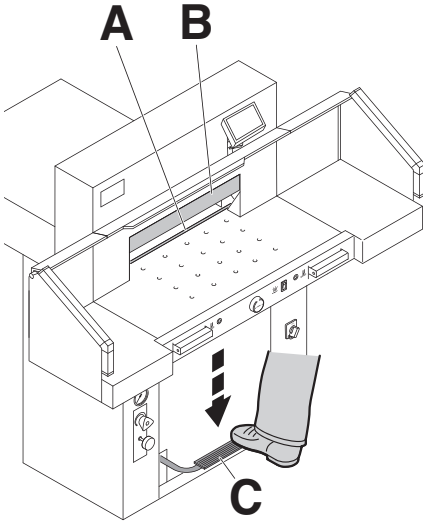

Optical cutting line indicator:

Optical cutting red line (A), indicates the position of the cut. Blade cuts on the front edge of the light beam.

Mechanical cutting line indicator:

The clamp (B) can be used as cutting line indicator for cutting. Pre-clamping can be performed using the foot pedal (C).

Only use the optical cutting line indicator and mechanical cutting line indicator when no exact cut is required.

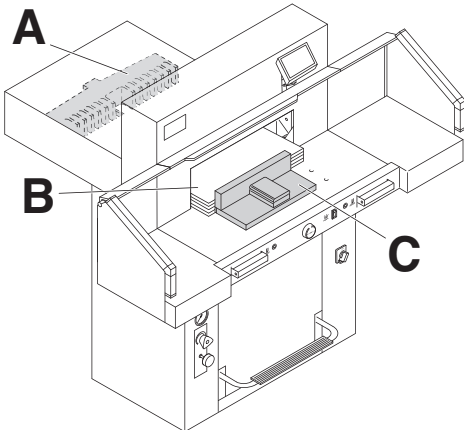

Position the paper on the backgauge (A) and side lays left or right (B). To move paper stacks, please use the paper knock-up block (C) provided. (Run backgauge to the front for turning the paper stack).

Operation

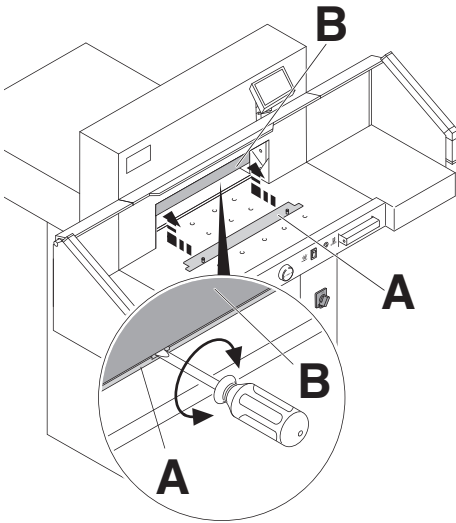

Clamp plate:

A clamp plate (**A**) is fitted to the machine to prevent pressure marks on sensitive material.

To dismantle:

- Remove the clamp plate (**A**) by turning the screwdriver (found in tool box) in the space between the clamp and clamp plate.
→ The remaining cut is 3,2 cm.

To mount:

- The clamp plate (**A**) is inserted to the top into the clamp (**B**).
→ The remaining cut is 6 cm (manual - handwheel), automatically 8 cm

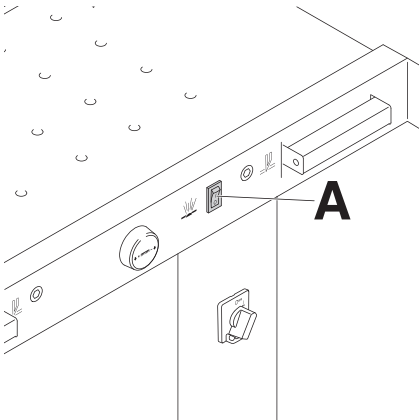

Air table

It is easier to position large stacks of paper when the airtable (**A**) is switched on.

Operation

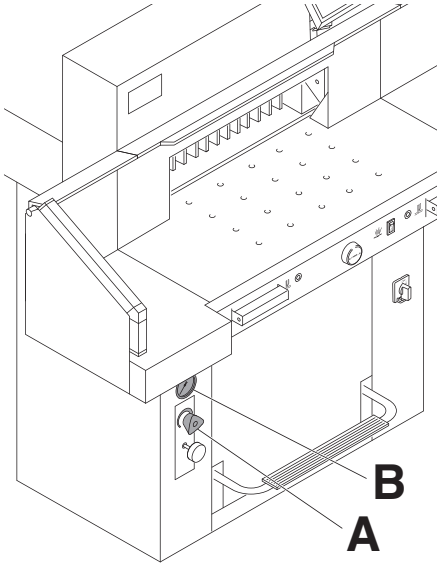

Setting clamping pressure

If necessary, set clamping pressure with setting wheel (A). If a cutting process has been activated, the oil pressure can be seen on the oil pressure indicator (B).

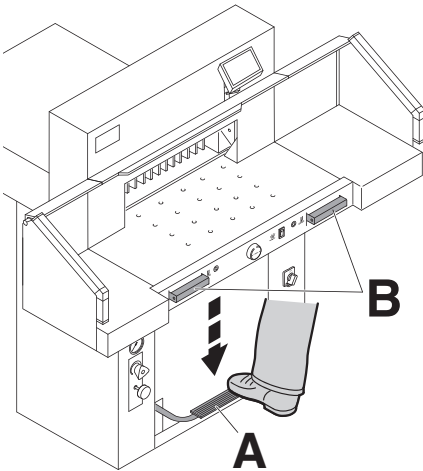

The clamp moves automatically when cutting is activated. The paper can be pressed in advance, with the foot pedal (A). Cutting is activated by pressing both buttons (B) on the front table.

Operation

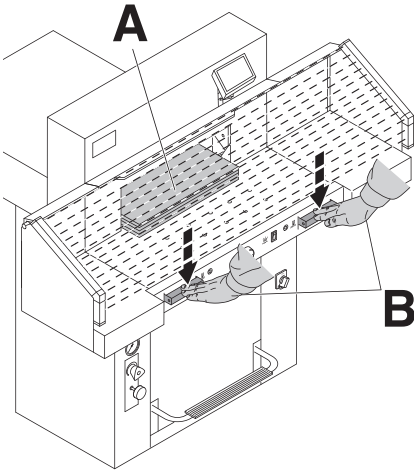

Cutting activation

Do not reach into the cutting area when the blade is in motion.

A cut can only be activated when the specified size is approached.

- Release the photo-electric beam guard (**A**).
- Press both actuators of the safety two-handed control system (**B**) simultaneously and keep them pressed until the paper is completely cut.

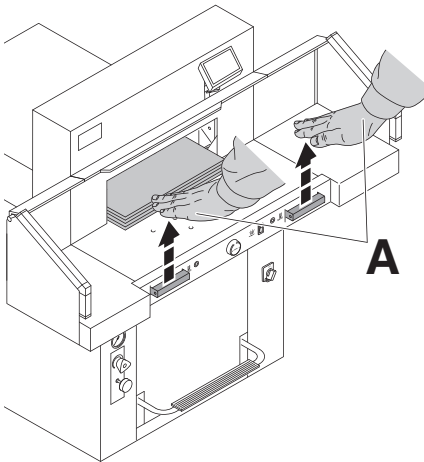

Cutting stop or interruption:

Release both actuators of the two-hand control (**A**).

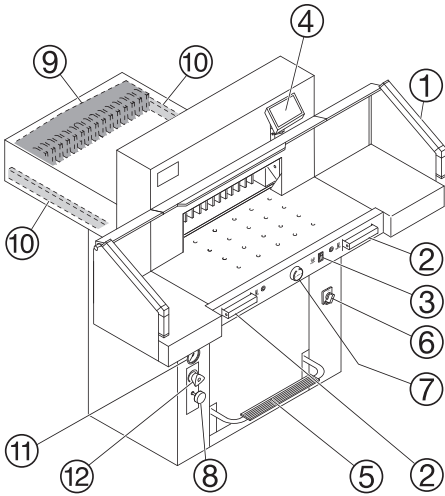





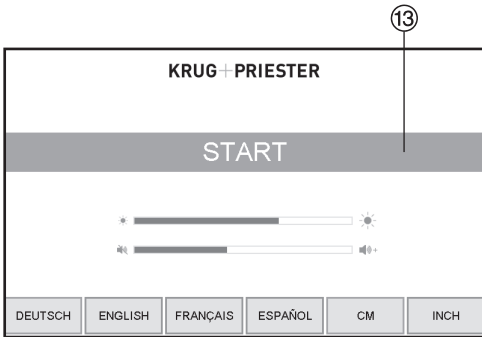











Operating elements

- ① - Safety light beam
- ② - Safety two-handed control system clamping and cutting
- ③ - Air table On-Off
- ④ - Backgauge control
- ⑤ - Foot pedal
- ⑥ - Main switch
- ⑦ - Hand-wheel for backgauge setting
- ⑧ - Blade locking
- ⑨ - Backgauge
- ⑩ - Side lay left and right
- ⑪ - Clamp pressure
- ⑫ - Clamp pressure adjustment



Start machine

- Main switch ⑥ to position "I".
Start screen appears
The following functions are changeable:
Brightness
CM/INCH
Touchtone volume
Language
Display / status photocell ⑳ green - red
- Press START ⑬ → backgauge ⑨ moves to the rear and searches for the reference position, wait until a measurement is shown in the display ④
5560 = 57.00 cm, 22.441 inches
- The DIN and free programmable measurements are recallable with the respective buttons ㉔.
Memory 1: A2, A3, A4, A5,
Memory 2: A6, A7, B3, B4
Memory 3:    
Memory 4:    
and in inch
Memory 1: 4 1/4", 5 1/2", 7", 8 1/2"
Memory 2: 11", 12", 14", 17"
Memory 3:    
Memory 4:    

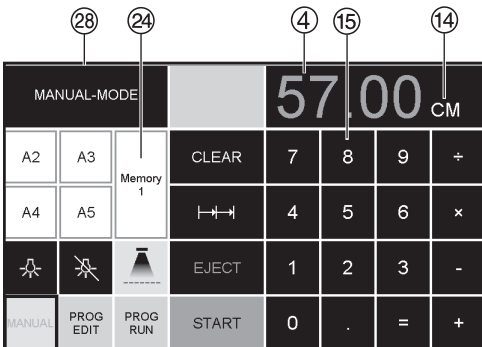

Operation

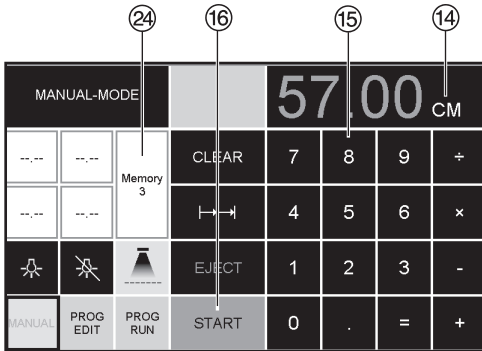

- In memory 3 + 4 (mm and inch) no measurements are saved. Until a first input of data the following will be shown in the corresponding fields: . **The measurements entered remain stored. They cannot be deleted but overwritten.**

How to program Memory 3 and 4

Press the memory button to enter the memory platform (3 or 4). Enter the required measurements or overwrite them. Press the button and keep it pressed until an acoustic signal sounds, the measurements have been saved now.

⚠ Warning!

Before storing or cutting a measurement please check if the correct measurement scale (cm or inch) see above is stored. (5560 = 57.00 cm, 22.441 inches) Is shown on the screen see .

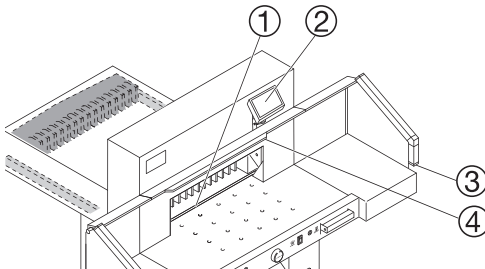

After 30 minutes the machine () switches to energy-saving mode. The machine is reactivated by touching the keypad area .

Bright LEDs illuminate the working area (). The LED button () has 3 switching steps

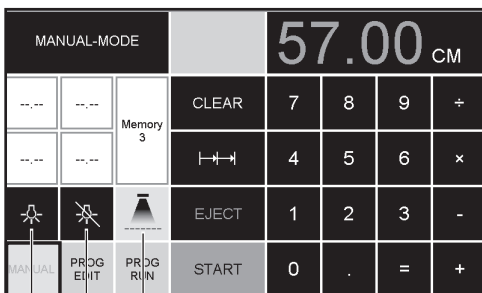

Press 1 x → brightness 3
 Press 2 x → brightness 2
 Press 3 x → brightness 1

Light OFF → .

Optical cutting line indicator → (ON/OFF) .

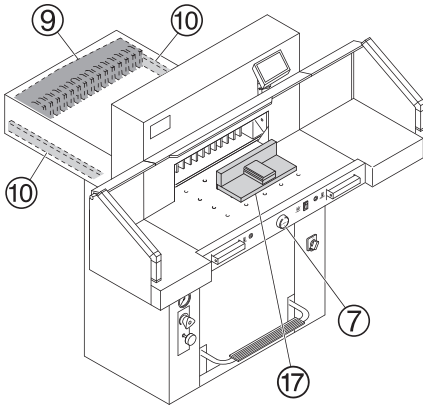

Cutting activation

⚠ Warning!

- Run backgauge to the front for turning the paper stack
- Do not interrupt the upward movement of the blade by performing switching procedures
- Wait until the display is green before activating a cut
- Blade must always be at the top and be covered by the clamp. Do not touch the blade (see safety information on page 34).

⚠ Risk of injury!

Cutting to specified dimensions

- Press **MANUAL**
- Enter dimension on the numerical key pad ⑮ → Measurement is shown in red (If a wrong dimension is entered this can be corrected by pressing the **CLEAR** button)
- Press **START** ⑯ → dimension is approached, → Measurement is shown in green
- Insert paper and move by means of the stacking angle ⑰ to the backgauge ⑨ and side lay on the left ⑩
- Release the cut.

MANUAL-MODE				57.00 CM			
A2	A3	Memory 1	CLEAR	7	8	9	+
A4	A5		←→	4	5	6	×
☀	☀	☀	EJECT	1	2	3	-
MANUAL	PROG EDIT	PROG RUN	START	0	.	=	+

Cut according to markings

- Press **MANUAL**
- Adjust the backgauge with the hand-wheel ⑦ to the back
- Insert paper and move by means of the stacking angle ⑰ to the backgauge ⑨ and side lay on the left ⑩
- Turn the hand-wheel ⑦ to the right until the marking on the paper to be cut is below the cutting line indicator
- The further the hand-wheel ⑦ is turned to the right, the quicker the backgauge moves. If the hand-wheel is turned to the left the backgauge will return quicker.

Operation

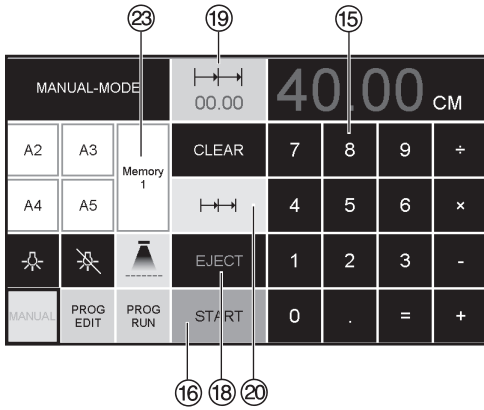

Eject function

If EJECT **18** is pressed instead of START **16**, after inserting the measurement **15**, the backgauge will advance forwards so that paper can be removed. Finally the backgauge moves to the last setting.

Multiple cut

- Enter the start dimension on the display **15**
- Advance to the measurement with the START **16**
- Push the paper to the backgauge
- Press multiple cut **20**
- Multiple cut sign appears top left together with the value 00.00 **19**
- Enter multiple cut measurement (appears in red letters)
- Press START → the backgauge advances by the multiple cut size
- This is repeated everytime a cut is activated.

Exiting program-mode

- Press multiple cut **20** (yellow). Multiple cut sign and value are deleted.

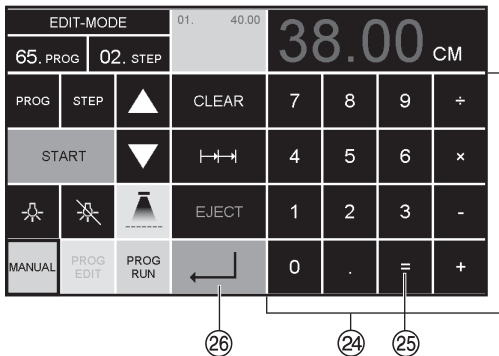

Calculator function **24**

- Calculate the desired measurement, e.g. $40 - 2 = 38$ **25** → ↓ **26** and the backgauge advances immediately to 38.

Operation

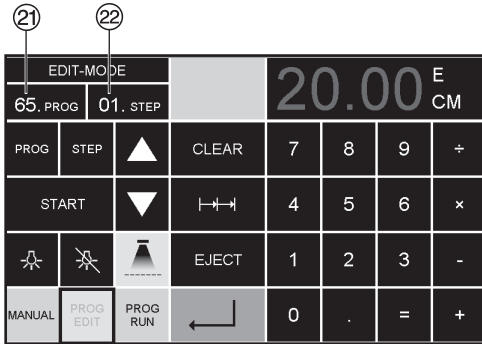

Programming

This control system enables you to store 99 programs with 99 programmable steps. One step represents one measurement. After entering the program numbers you are able to change between several program steps with the button ▼ and ▲. First figure on display ②① = program number. Second figure on display ②② = program step.

Each program step corresponds to one dimension. The indicated program step can be overwritten at any time. These programs remain stored when the machine is off.

Entering a program

- Press **PROG EDIT** → "Load program no." appears
- Enter program number 01 ... 99, with ↵ (Top number ②① on display = program number)
- If measurement is shown on the display the program is reserved, select another program
- Program step "01 Step" 00.00 ②② appears. (Second figure on display ②② = program step.)
- Enter dimension, or move the backgauge to the desired measurement with the hand-wheel ⑦
- Store the measurement ↵, next program step appears.
- Enter the next measurement and with Enter ↵ store the measurement etc.
- Should the entered program be required immediately → press **PROG RUN**
- Press Enter ↵
- Press START
- Escape the program mode press **MANUAL**

Cancel a program

- Press **PROG EDIT**
- Scroll with PROG until "Delete program no." appears
- Enter Program number
- Press Enter ↵
- Press Enter ↵.

Operation

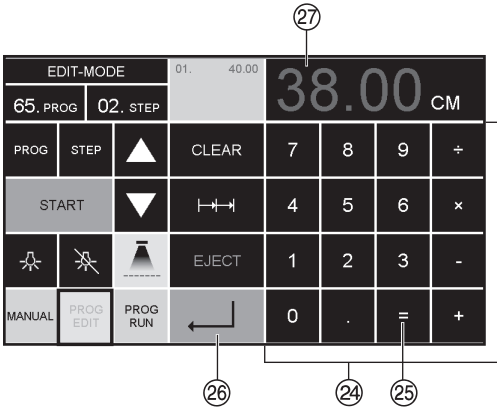

Calculator function ②④ in programming

- Press **PROG EDIT**
- Enter program number
- Enter the 1st program step e.g. start-up measurement 40 cm
- Store the measurement with enter ↵ ②⑥
- Calculate the desired measurement e.g. $40 - 2 = ②⑤$ → ↵ ②⑥, the calculated measurement 38 ②⑦ flashes.
- Pressing the Enter-key ↵ ②⑥ again, the calculated measurement is saved in the corresponding step.

Operation

RUN-MODE		02. 25.00	29.98 CM			
22. PROG	01. STEP	03. 20.00				
		01. 30.00				
PROG	▲	CLEAR	7	8	9	+
STEP	▼	MODIFY	4	5	6	x
☀	☀	☀	EJECT	1	2	-
MANUAL	PROG EDIT	PROG RUN	START	0	.	= +

23

Adapting a program when the printer's imprint deviates

- Press **PROG RUN** → "Load program no." appears
- Enter program number 01 ... 99, and with 2 x Enter ↵ proceed to Step 1
- Correct the cutting position of the backgauge with the hand-wheel
- **MODIFY** 23 appears on the screen and the measurement flashes
- To store press **MODIFY**
- Release a cut and turn the paper
- If the printer's imprint deviates it can be corrected during the first two cuts via the hand-wheel – see above
- Correction is only possible during the first two cuts
- After leaving the **PROG RUN** mode the original data is stored again.

Delete a step

- Press **PROG EDIT**
- Enter program number, confirm with Enter ↵
- Select program step with the arrow keys ▲ and ▼
- Scroll with **STEP** until "Delete step no." appears, Press 2 x Enter ↵.

Insert a step

- Press **PROG EDIT**
- Select a program, confirm with Enter ↵
- Scroll with **STEP** until "Insert step no." appears
- Enter insert position e.g. 02
- Confirm with Enter ↵
- Enter a measurement
- Store the measurement with ↵
- The cutting position can be shown on the screen with the arrow keys ▲ and ▼.

Changing a program step

- Press **PROG EDIT**
- Select a program, confirm with Enter ↵
- Scroll with **STEP** until "Load step no." appears
- Enter step position e.g. 03
- Confirm with Enter ↵
- Enter a new measurement, Store the measurement with ↵.

Operation

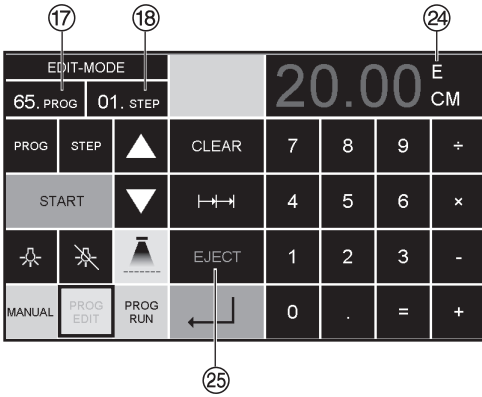

Eject function program

- If a short measurement e.g. 30 cm and then a long measurement e.g. 40 cm is cut at the start of a program then it is wise to insert an EJECT ²⁴ after the first cut so that the paper is pushed to the front.
- The EJECT function can be added each time a measurement is entered and ejects before advancing to the next measurement. When the eject function is programmed an "E" ²⁴ appears top right in the display.
- Inserting an Eject function subsequently in the program. Select a program and advance to the step to be changed with the arrow keys ▲ and ▼ Enter the new measurement and before activating the enter button ↵ press EJECT ²⁵.

Example of a program eject function

- Press **PROG EDIT**
- Enter program number e.g. 08
- Press Enter ↵
- 1. Enter program Step e.g. 30 cm
- Press Enter ↵
- 2. Enter program Step e.g. 40 cm
- Press EJECT and with Enter ↵ store the dimension.

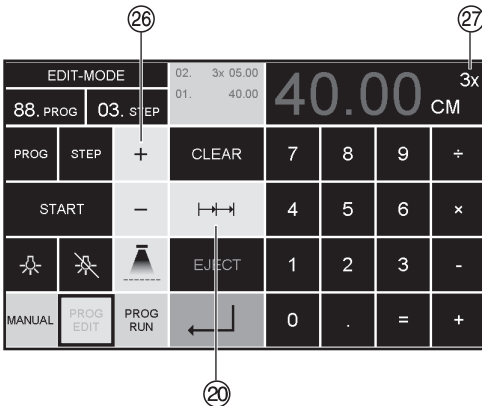

How the example works

- Press **PROG RUN**
- Enter program number 08
- Press Enter ↵
- Press START, Measurement is approached
- Insert paper
- Release cut 1
- Eject (Ejection is completed, turn the paper)
- The backgauge moves to program step 2
- Release cut 2

Multiple cut program

- Press **PROG EDIT**
- Enter program number
- Enter the 1. program step e.g. start-up measurement 40 cm
- Store the measurement with Enter ↵
- Press the multiple cut symbol ↔ ²⁶
- Enter the number of cuts ²⁶ with the + button ²⁷ (max. 15 cuts) followed by the multiple cut size (cutting width).
- Store with Enter ↵

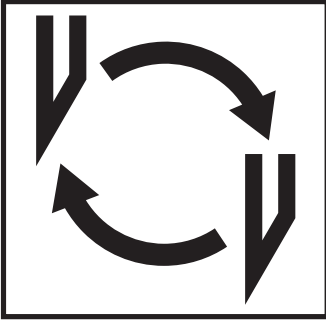

If the cutting quality decreases:

- Check the cutting depth (see page 34).
- Check the cutting stick (see page 28).
- Replace or grind the blade (see page 24 - 34).

The blade cannot be ground if the blade height is less than 8,2 cm / 3,23 inches. A new blade must be used.

The blade may only be ground by a qualified supplier or from the manufacturer Krug & Priester, D-72336 Balingen.

⚠ Danger! Risk of injury!

The blade is extremely sharp. Do not extract or transport the blade without protection. Changing the blade may only be performed by trained staff.

Blade and cutting stick replacement

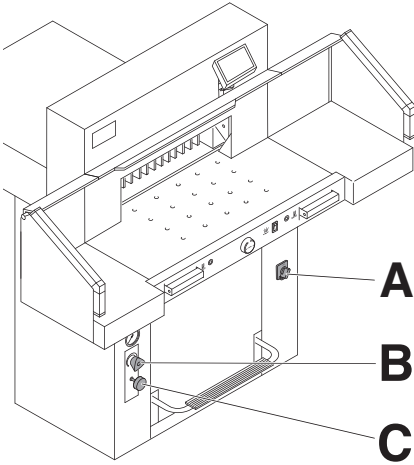

- Set mains switch (**A**) to position "I" .
- Set clamping oil pressure (**B**) to min. 50 bar.
- Press in blade locking key (**C**).
- Activate cutting → blade remains in lowest position.
- Set mains switch to position "0".

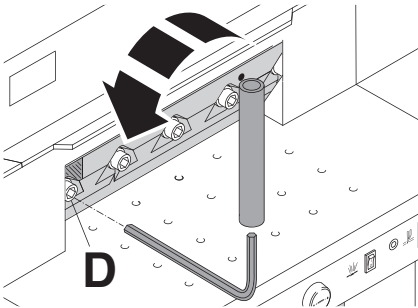

Remove the left screw (**D**), using the extension.

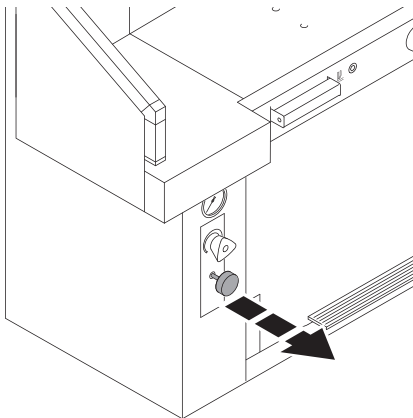

Pull out blade locking key → blade moves to the top.

Blade and cutting stick replacement

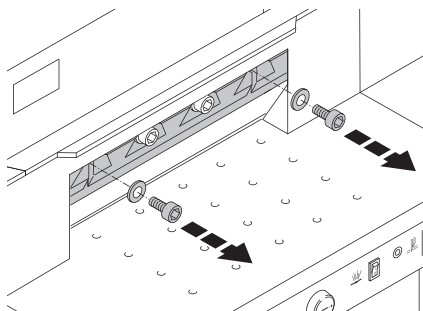

Remove both outer screws.

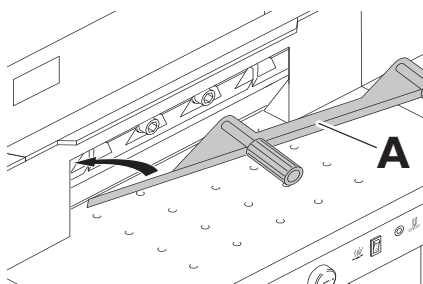

Mount blade changing tool (A).

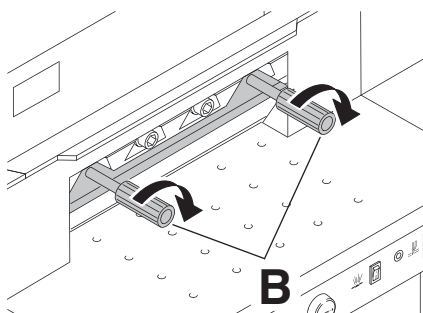

Tighten screws (B).

Blade and cutting stick replacement

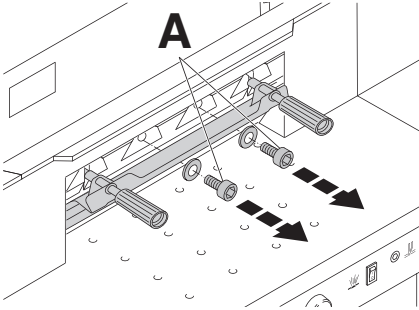

Remove remaining two screws (A).

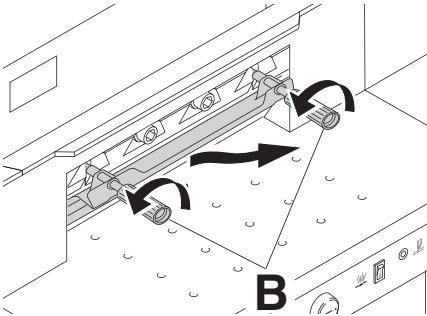

Simultaneously slightly loosen both screws (B) and remove blade with blade changing tool.

Weight of blade approx. 5 kg.

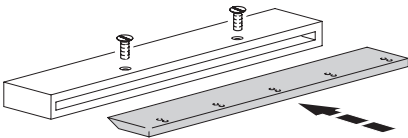

Place the blade into the blade carrier and screw it into place.

Blade and cutting stick replacement

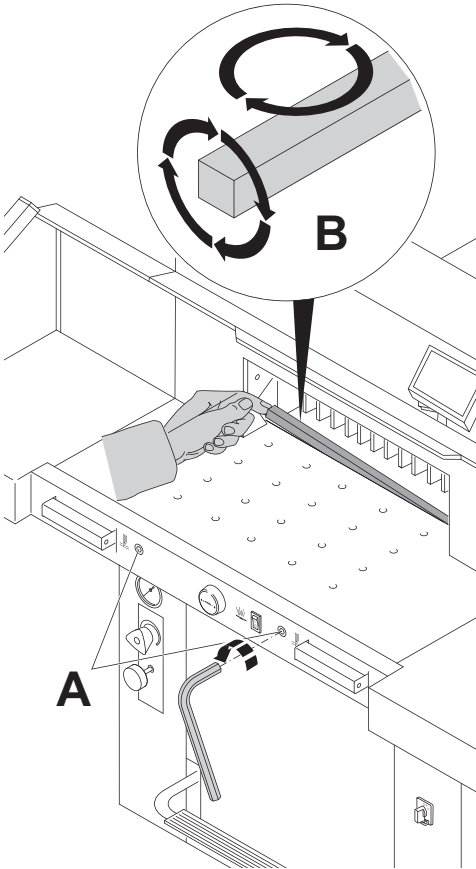

- Loosen screws (A) (SW4).
- Remove cutting stick (B).
- If needed the cutting stick can be turned or exchanged.
- Slightly tighten screws (A).
- The cutting stick can be used eight times.
- Turn screw (C) as far as possible to the right (Otherwise the first cut will be too deep).

⚠ **Danger! Risk of injury!**

Replacing the cutting stick (not the blade)

- Loosen screws (A) (SW4).
- Remove cutting stick (B).
- Turn the cutting stick (the non-used side must be near to the blade).
- Slightly tighten screws (A).
- Turn screw (C) as far as possible to the right (Otherwise the first cut will be too deep).

⚠ **Danger! Risk of injury!**

Cutting test after replacing the cutting stick (not the blade)

- Insert the paper and release the cut.
- If the last sheet of paper is not cut along the entire length turn the blade adjusting screw (C) 1/6 turn to the left.
- If the last sheet is still not completely cut repeat this process until the last sheet is cut along the entire length.

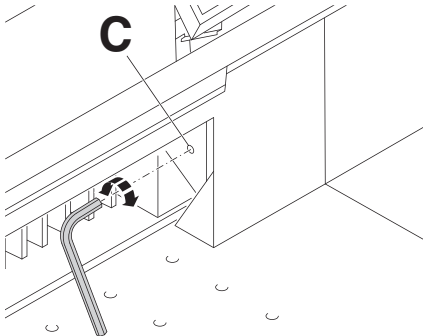

Blade and cutting stick replacement

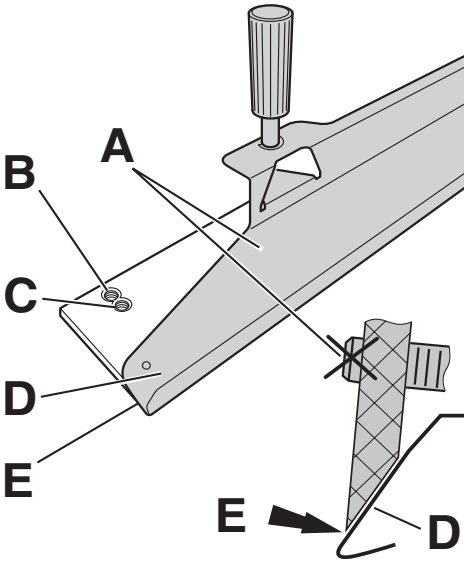

Take the exchange blade carefully out of the blade box and screw it to the blade changing tool (D).

- Check, if when using the upper threads (B), the blade (E) is protected.
- The blade is not protected → Use the lower thread (C) for fixing. The screws (A) may not exceed at the rear side of the blade.

⚠ Danger!

Blade (E) must be protected.

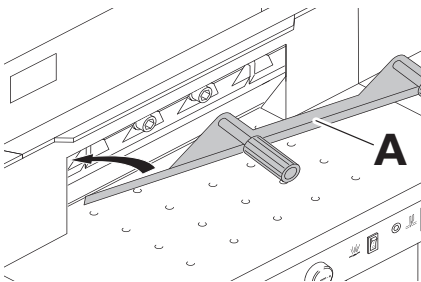

Mount the blade with the blade changing tool (A) ...

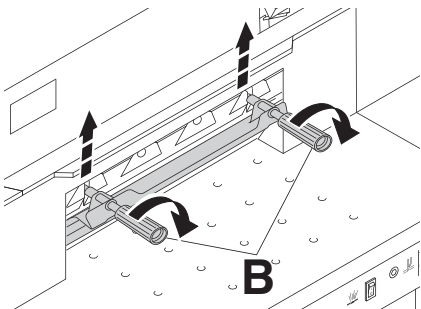

... and tighten with screws (B) in upper position.

Blade must be in the upper position.

Blade and cutting stick replacement

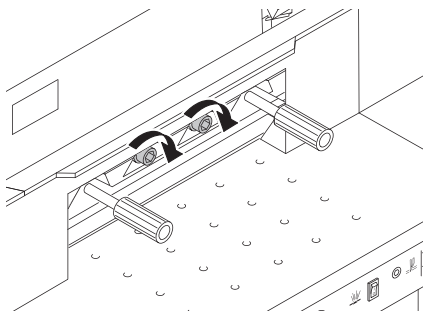

Screw in middle screws and tighten.

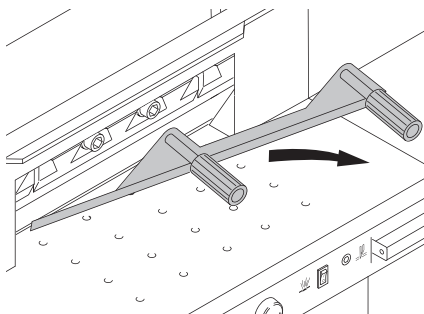

Remove the blade changing tool.

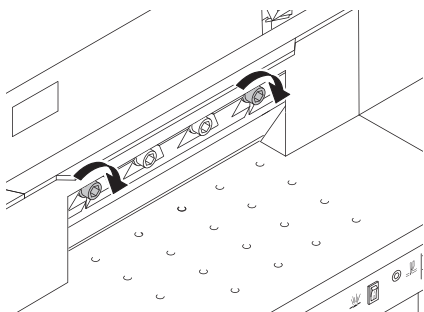

Slightly screw in outer screws.

Blade and cutting stick replacement

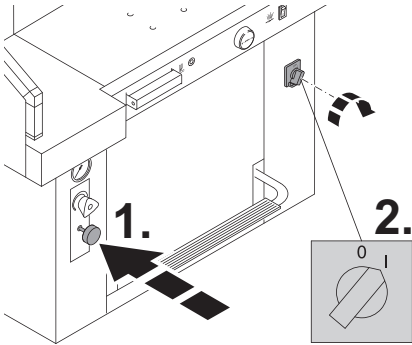

- Press in blade locking key.
- Set main switch to position "I".

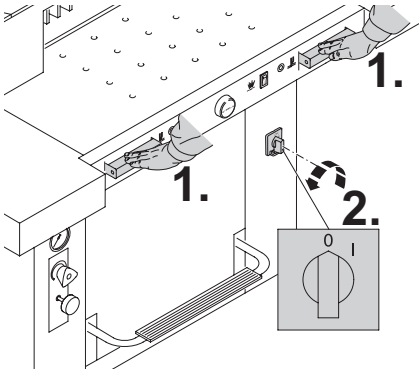

- Activate cutting → blade remains in the lowest position.
- Set main switch to position "0".

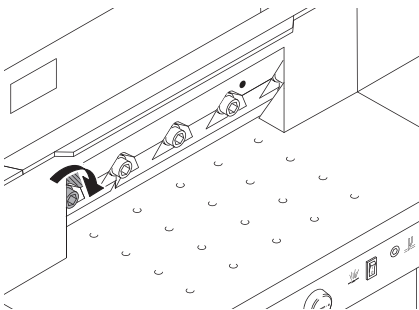

Screw in slightly the left screw.

Blade and cutting stick replacement

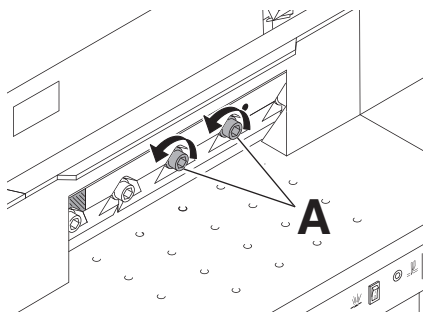

Loosen slightly screws (**A**) so that the blade slides onto the cutting stick.

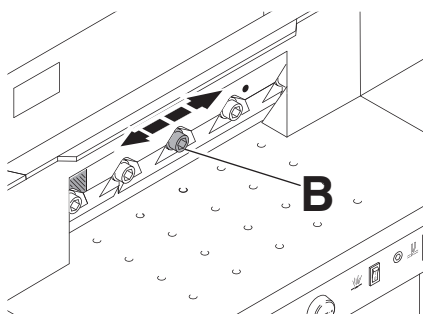

Push the blade and screw (**B**) as far as possible to the left or right and then centralize them. → The blade must rest on the cutting stick.

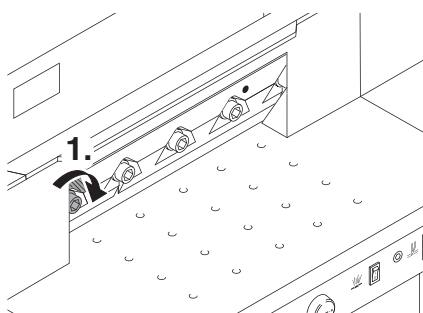

Push in the first screw on the left side and tighten.

Blade and cutting stick replacement

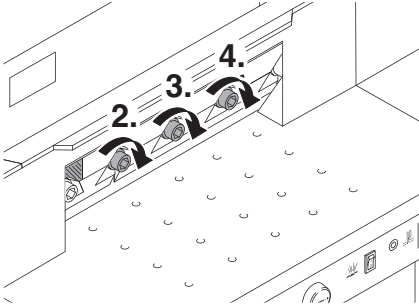

Tighten the remaining 3 screws beginning from the left.

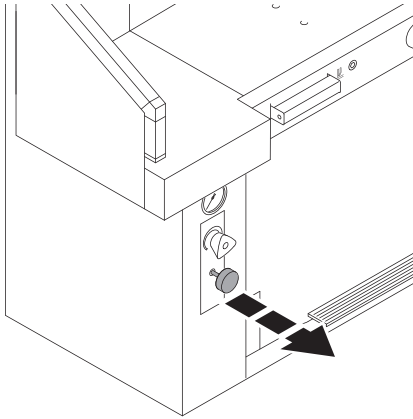

Pull out blade locking key
→ blade moves to the top.

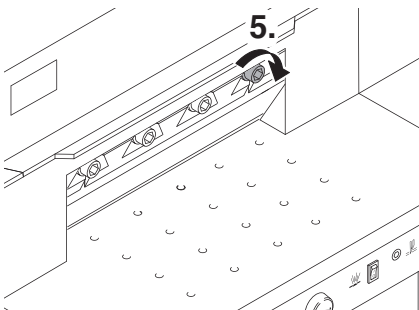

Tighten the screw which is visible at the right.

Blade and cutting stick replacement

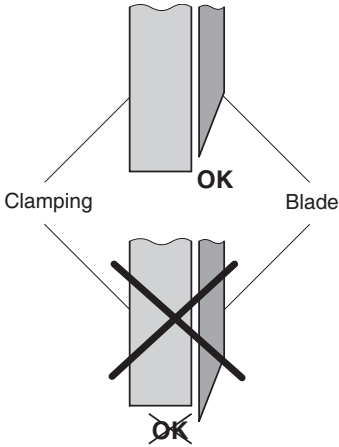

⚠ Danger!
Blade must always be covered by the pressing bar.

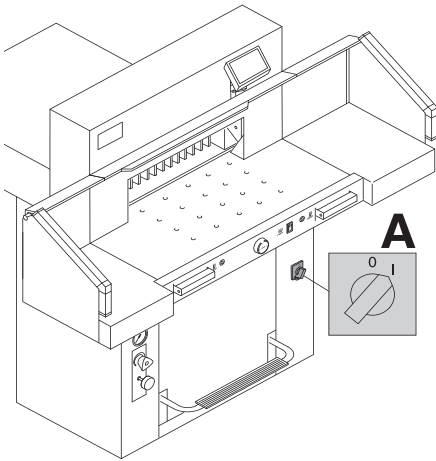
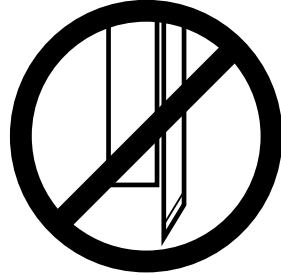

Turn main switch to position "I".

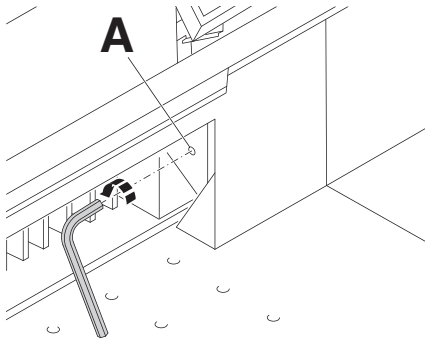

Paper cutting test. If the last sheet or several sheets are not completely cut, gradually turn the knob for blade depth adjustment (A) 1/6 turn to the left until the paper is cut along the entire length. Do not set too low as blade will soon become blunt.

Maintenance and cleaning

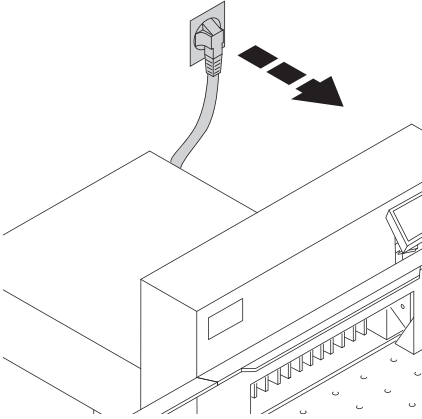

Maintenance work may only be performed by trained staff.

⚠ Danger!
Disconnect the mains before starting any service work or before removing the cover.

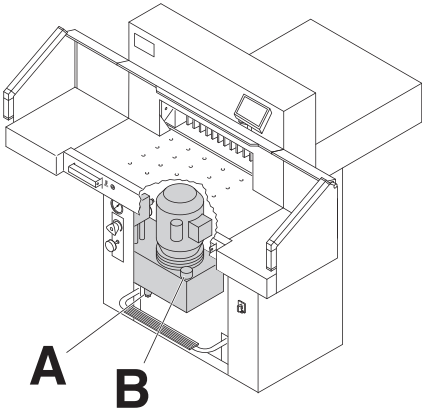

Grease and oil the machine according to the lubrication diagram after 1000 operating hours or once a year. If the machine is subject to excessive load then twice a year.

The hydraulic oil must be changed every 2000 operating hours or every 2 years.

Type of oil:
Aral Vitam DE 46 to DIN 51562. Volume:
approximately 7 litres.

(A) Drain screw
(B) Oil stick

- Check that the hydraulic pump and screws are not leaking. If necessary tighten the retaining nut.
- Check pressure. Maximum pressure is 150 bar.

Maintenance and cleaning

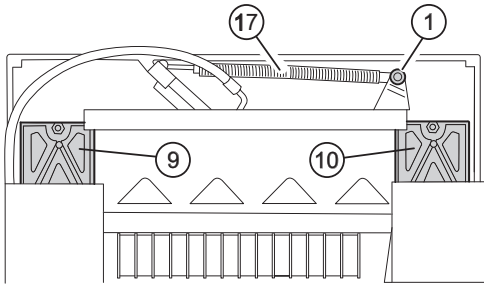

Lubrication schedule

Lubricate (1) to (8).

Type of oil: SAE10 to SAE50 all types.

Grease (9) to (17)

(9+10) Blade guidance

(11+12) Clamp guidance

Type of grease: Use special grease for cutting machines:



No. 9000 625

Oil hinges of the foot clamping device at the front area of the machine room.

Type of oil: SAE10 to SAE50 all types.

With more than 5 hours of use per day, the service must be performed more often.



No. 9000 625

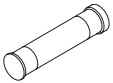

No. 9800 933



No. 9001 828

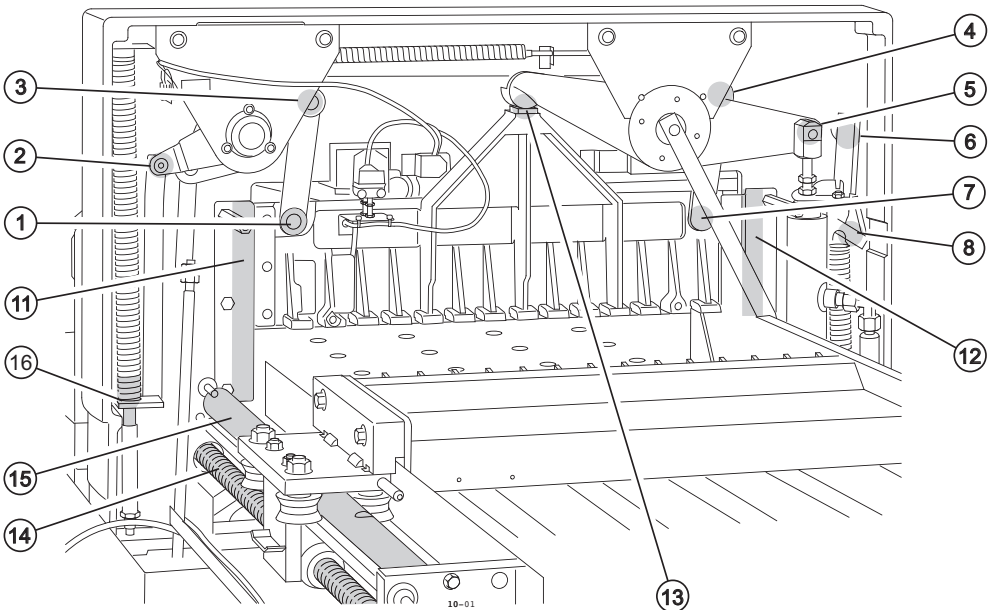

Maintenance and cleaning

Next Maintenance

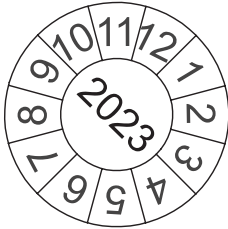

Krug & Priester GmbH & Co. KG
72336 Balingen - Germany

Parts & Service HOTLINE

Germany: +49 7433 2690
France: +33 3 8820 5435
North America: +1 843 552 2700
All other countries: Please contact
your local distributor
www.krug-priester.com

Annual inspection

To maintain the operational safety and to prevent premature wear, we recommend an annual inspection and maintenance of the machine by a qualified service technician.

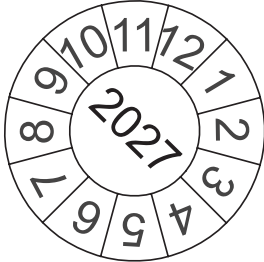

Safety test

The safety regulations are according to the regulations of the country where the cutting machine is operated. The manufacturer recommends a safety check is made every 5 years by an authorised service team.

Possible malfunctions



Machine does not function!

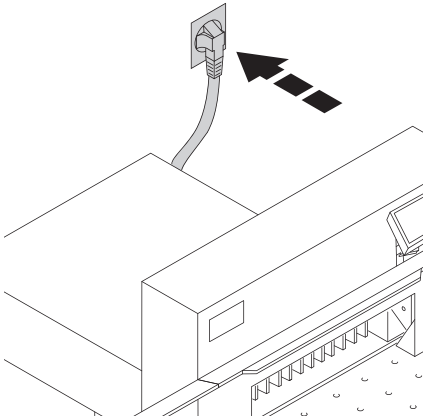

Is the machine plugged in?

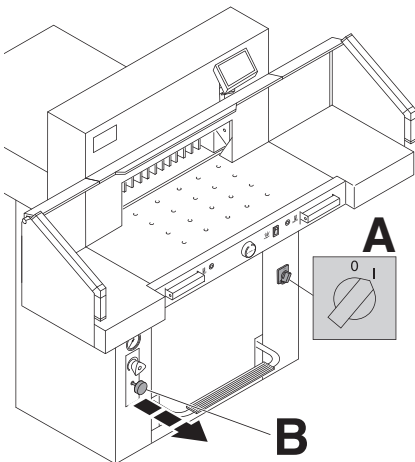

- Main switch to position "I"? (**A**)
- Blade locking facility (**B**) must be pulled out.
- Push in the fuses in the back of the machine F1, F2, F3.
- Check the units fuse and the on-site circuit breaker.

Possible malfunctions

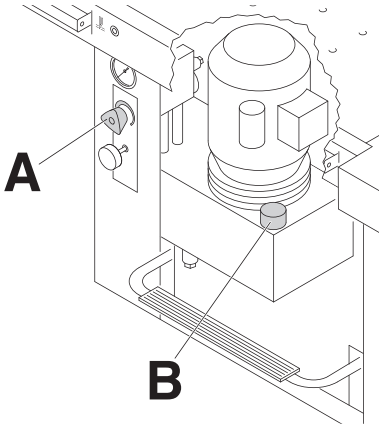

- Oil pressure set too low. → Increase oil pressure at rotary control (A).
- Hydraulic oil shortage. → Check hydraulic oil level (B), if necessary, top up.

Information

Clamp bar
is active,
please release clamp

"Information" Clamp bar is active, please release clamp

- → Operate the foot pedal (clamping) again.

Possible malfunctions

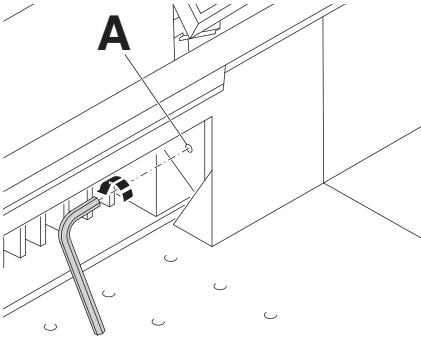

Does not cut through the last sheet.
→ Reset the cutting depth (**A**) ...

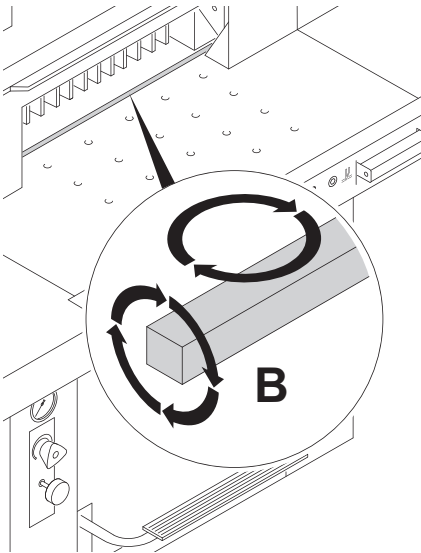

... or turn / replace the cutting stick (**B**).
(See page 29 "Blade and cutting stick replacement").

A reduction in the cutting quality indicates that the blade must be sharpened or a blade change is necessary.

Possible malfunctions

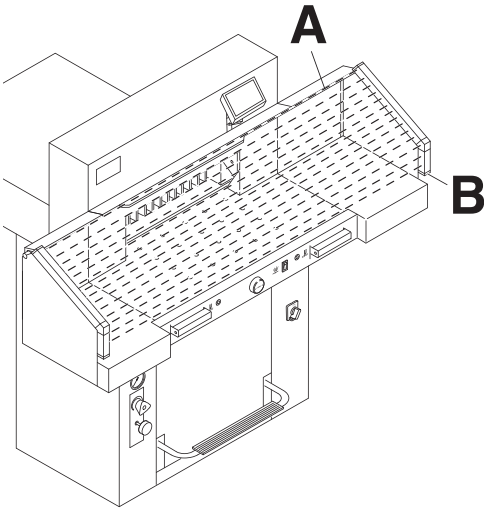

Trouble shooting-light beam

Cut cannot be activated:

- Remove all items obstructing the safety area (A)
- (B) Green = o.k. / ready for operation
Red = light beam is interrupted or error

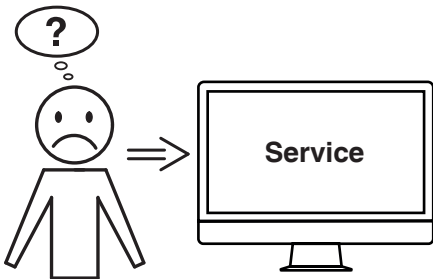

Did none of the specified solutions help you with your problem?

- Contact: Service
- www.krug-priester.com
 - service@krug-priester.com

Accessories

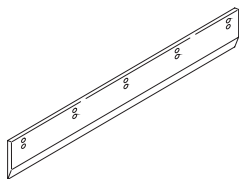

HSS - Blade
• No. 9000 138

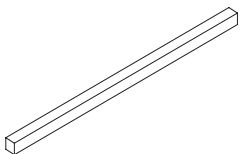

Cutting stick (6 pieces)
• No. 9000 238

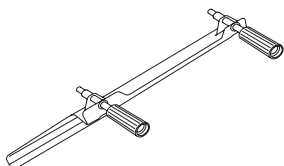

Blade changing tool ¹
• No. 9000 525



Grease tube ¹
• No. 9000 625

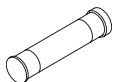

Grease cartridge
• No. 9800 933



Brush
• No. 9001 828

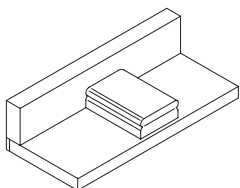

Paper knock-up block ¹
• No. 9000 521

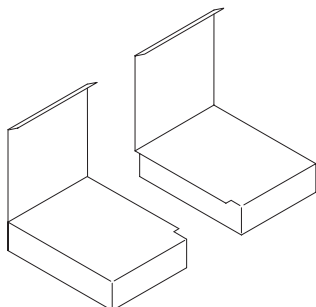

Side tables left and right
• No. 9000 536

¹ Included in delivery

Technical data

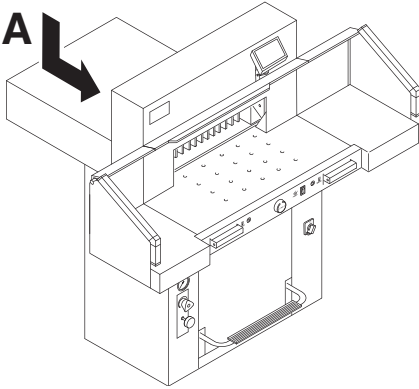

Technical data:

Power supply: 230 V / 50 Hz / 8,5A / 1~
120 V / 60 Hz / 12A / 1~

Leakage current: < 3,5mA

Power cord gauge: min. 1,5mm² (230V)

Power cord gauge: AWG 12 (20A) (120V)

Cutting length: 550 mm

Cutting height: 95 mm

Table depth: 570 mm

Sound level EN 13023 : < 70 dB(A)

Minimum space requirement

(width x depth x height)

without side tables (mm): 1070 x 1400 x 1370

with side tables (mm): 1630 x 1400 x 1370

Clamping pressure: 200 daN bis 1100 daN

Weight without side tables: 369 kg

Capacity of hydraulic oil: 7 l

Aral Vitam DE 46 to DIN 51562. Used oil must be disposed of at the authorised place.

Ambient operating temperature: 10 °C - 60 °C

Air humidity (not condensating): 15 % - 95 %

The exact technical specifications can be found on the technical specifications sticker (**A**) on the machine. To claim under guarantee, the machine must still carry its original identification label. A wiring diagram is found in the electrical switch box.

Safety beam guard

Total reaction time: 110 ms

Resolution 14 mm/minimum distance: 250 mm

Resolution 22 mm/minimum distance: 284 mm

Resolution 39 mm/minimum distance: 420 mm

Subject to alteration without notice.

Technical data



I.T.E. Listed 802 D



This machine is approved by independent safety laboratories and is in compliance with the EC-regulations 2006/42/EG and 2014/30/EU.

Sound level information:

Sound measurement to EN 13023 :
72,5 db (A)

Subject to alteration without notice.

Technical data



The company Krug + Priester has the following certifications:

- Quality management system according to DIN EN ISO 9001:2015
- Environmental management system according to DIN EN ISO 14001:2015
- Energy management system according to DIN EN ISO 50001:2018

EC-declaration of conformity

EC-declaration of conformity

- Herewith we declare that

5560 GS ID No. 11055101 UL ID No. 10055101

- complies with the following provisions applying to it

2006/42/EG:

EC Machinery directive

2014/30/EG:

EMV Electromagnetic compatibility directive

2011/65/EU, 2015/863/EU

RoHS directive

- Applied harmonised standards in particular

**EN 60204-1; EN 1010-1; EN 1010-3; EN 55014-1; EN 55014-2;
EN 61000-3-2; EN 61000-3-3; EN ISO 12100; EN 61496-1; EN 61496-2;
EN ISO 13857; EN ISO 11204; EN 13023; EN ISO 13849-1;
BS EN 60204-1; BS EN 1010-1; BS EN 1010-3; BS EN 55014-1; BS EN 55014-2;
BS EN 61000-3-2; BS EN 61000-3-3; BS EN ISO 12100;
BS EN ISO 13857; BS EN ISO 11204; BS EN 13023; BS EN ISO 13849-1**

14.02.2022

Date

Authorized representative for technical documentation



Krug & Priester GmbH & Co. KG
Simon-Schweitzer-Str. 34
D-72336 Balingen (Germany)

- Managing Director -

Remarks:

• Document Shredders •



• Trimmers and Guillotines •

