

Guillotines

EN Operating Instructions

IDEAL 7260



Table of Contents

Safety precautions	3
Intended use	4
Installation	9
Startup	10
Operation	13
Operating elements	16
Blade and cutting stick replacement	24
Maintenance and cleaning	33
Annual inspection / Safety test	35
Possible malfunctions	36
Accessories	43
Technical data	44
EC-declaration of conformity	47

Safety precautions



Please read these operating instructions before putting the machine into operation and observe the safety precautions.
The operating instructions must always be available.



Children must not operate the machine!



Do not reach beneath the blade!



Never leave the blade unattended!
Do not extract or transport the blade without protection! (See page 27 and 29).
⚠ Danger! Risk of injury!

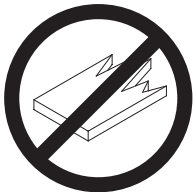

Do not cut hard materials or materials which may splinter!

Safety precautions / Intended use



Do not use any spray cans with flammable content near to the cutting machine!



Do not use any flammable cleaning agents.

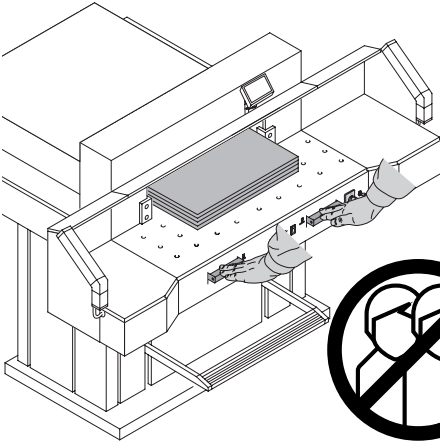

Intended use

The machine is designed for cutting stacks of paper to a specified size.

This machine is constructed for "one-man operation" only!

⚠ Warning! Clips or similar damage the cutting blade.



Safety precautions

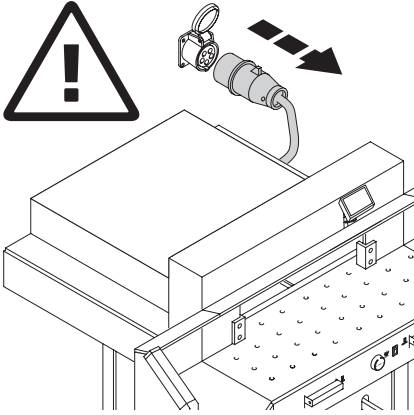

Disconnect from the mains before starting any service work or before removing the panels!

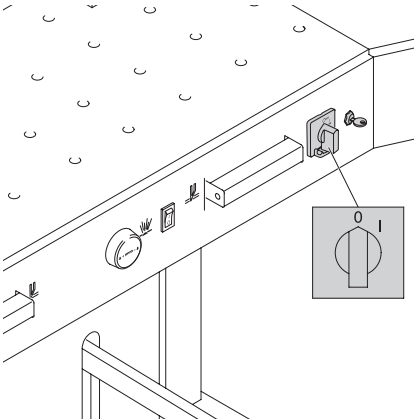

Replacement of blade and cutting stick may be performed only when the main switch is switched off!

Safety precautions

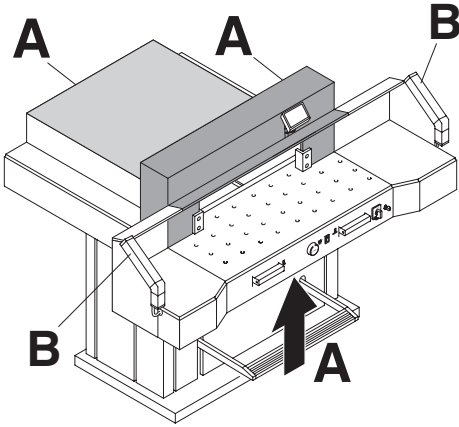

All components which may endanger the operator are covered by a guard (A).

Do not operate the machine without the following safety devices:

- Panels, tightly screwed (A).
- Safety beam guard (B).

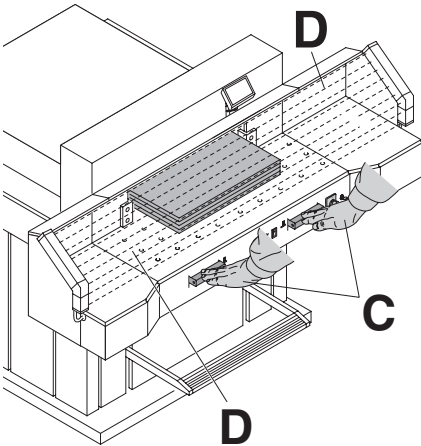

The cutting action, which is dangerous to the operator, is protected by a two-handed control system (C) and safety beam guard (D).

Safety precautions

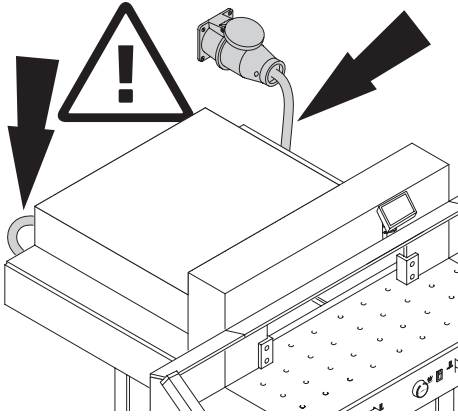

Protect mains cable against heat, oil and sharp edges!

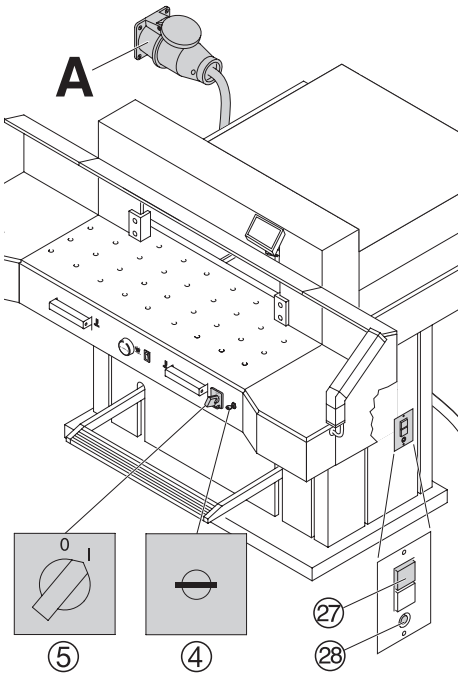

Standard machines are factory-set as follows:

- Power supply:
400 V, 3P+N+PE
220 V, 3P+PE
- Frequency 50 / 60 Hz.

Machine does not function

- Is the machine ⑤ switched on?
- Is the key-switch ④ on.
- Is the green overload switch ⑳ pressed?
- Is the black overload switch ㉑ pressed?
- Check on-site fuse.

If the machine still does not function then the rotation must be reversed.

The machine is wired according to the IEC standards. We recommend that alterations to the rotary direction be made in the socket. It is also possible to make alterations in the plug by exchanging "L1" and "L2".

⚠ Danger!

Incorrect exchanging of the connections will endanger the operator.

This work must be carried out by an electrician.

Safety precautions

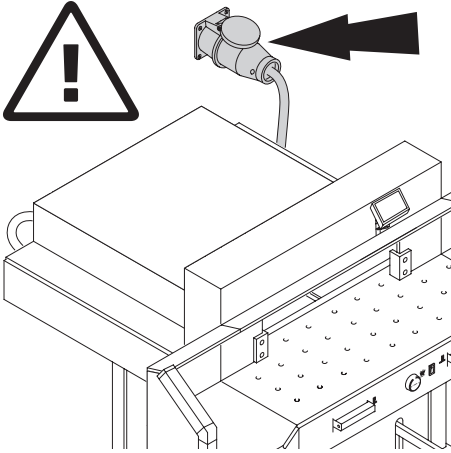

Ensure free access to mains!

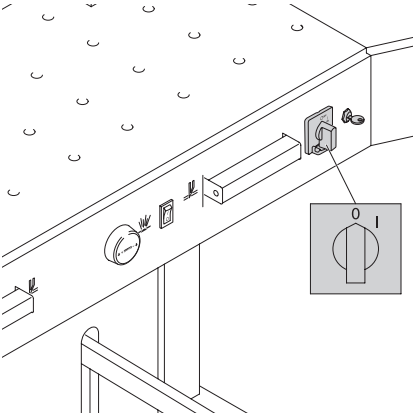

When not in use for a longer period switch off.
(Main switch to "0").

Installation

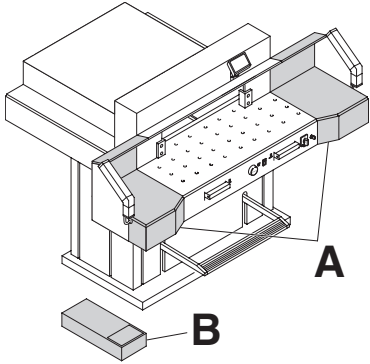

The machine is delivered ready for operation. 6 strong people are required to lift the machine from the pallet. Side tables, left and right, (A) are available as accessories.

Attach the side tables to the front table so that the upper surface is level.

(Screws and nuts are in a plastic bag in the tool set (B)).

Reassemble the safety light beam.

For transport through narrow doors:

- Remove side tables

⚠ Danger!

The machine must not be put into operation without the safety light beam.

Assemble the side tables.

Remove the light beam. (1. - 2.)

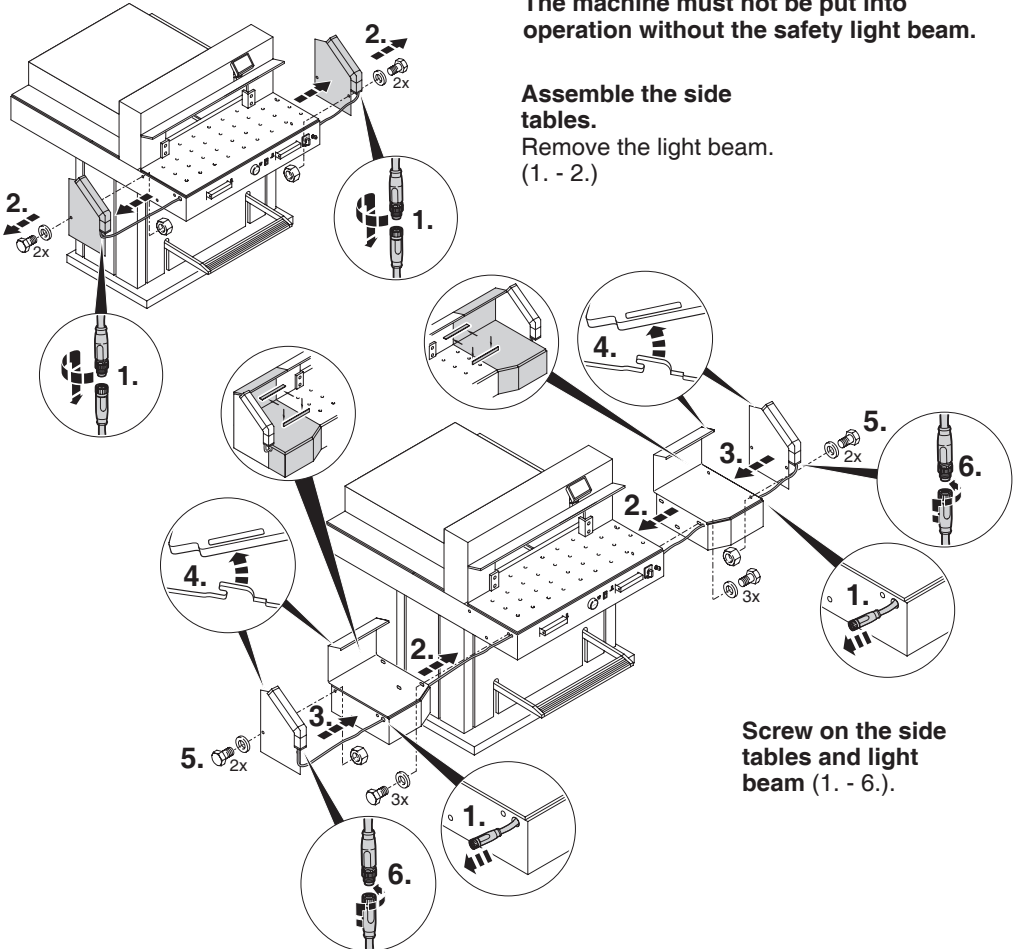

Screw on the side tables and light beam (1. - 6.).

Startup

Plug into socket.

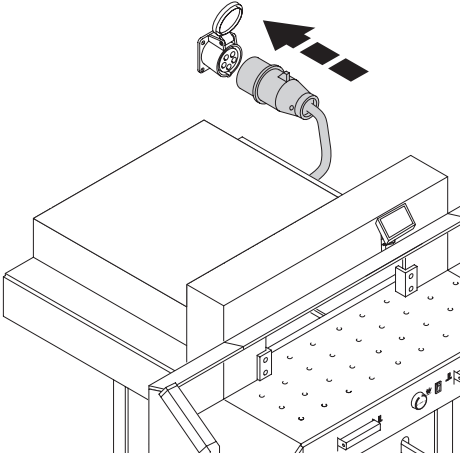

Display (C) is pivotable. By loosening the allen head screw (D), (allen wrench is in the tool box) the display can be pivoted within the elongated hole. Tighten allen screw again.

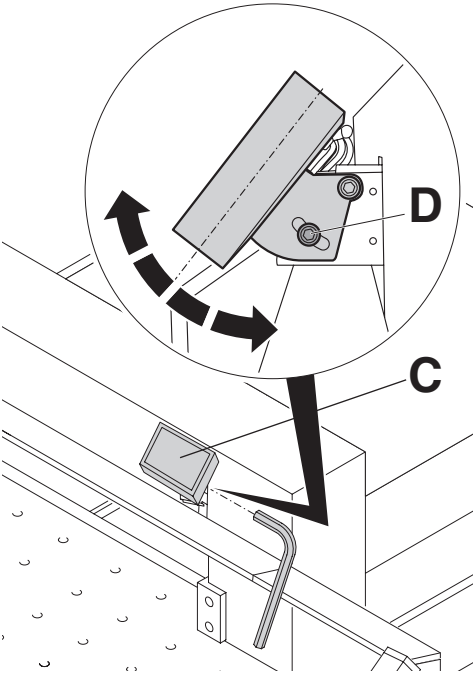

Startup

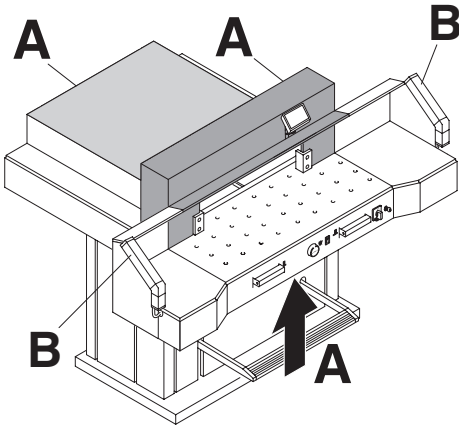

The machine may only be operated, if the operating instructions and the safety instructions have been understood. Before each use, check the safety equipment for completeness and functionality.

- All covers have to be mounted (A).
- Safety beam guard must be mounted (B).
- The release for cutting is allowed only if the two-hand safety device is operated at the same time (C)
- **Safety light beam:**
If the test rod (E, tool kit) is held into the protective field (D), an activated work cycle must be stopped immediately.

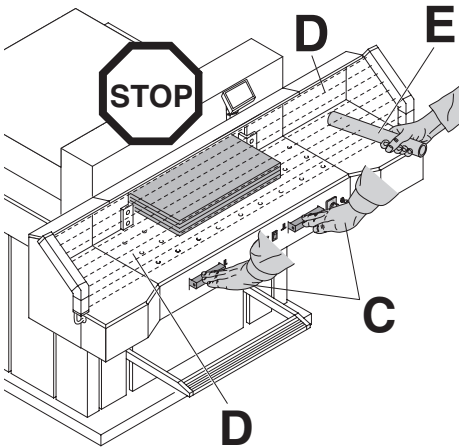

We recommend you keep a record of your test results.

Startup

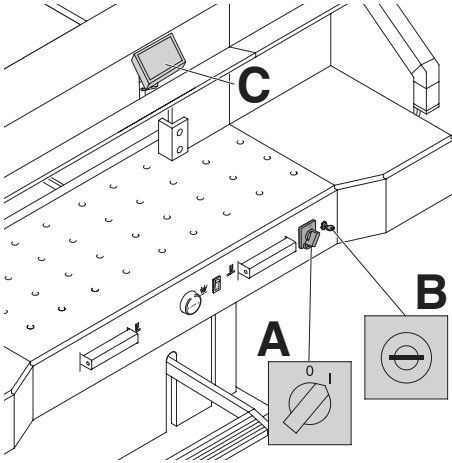

Position the main switch to "I" (A). Insert the key for the control system and turn it to the right (B). Press **Start** (C) machine will automatically go to 72 cm or 28,346 inches.

The machine is now ready for use.

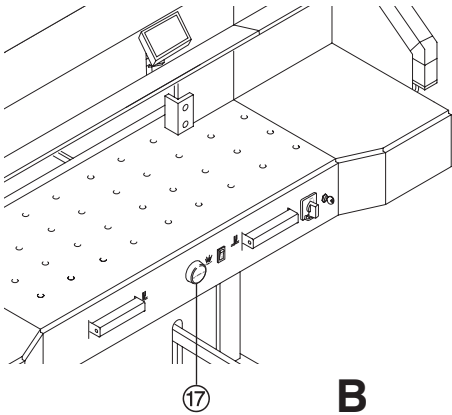

The measurement is set as follows:

- manually with the electric hand-wheel (17)
- by programming the cutting dimensions (A). Dimension is shown on the display in inches or cm (B).



Operation

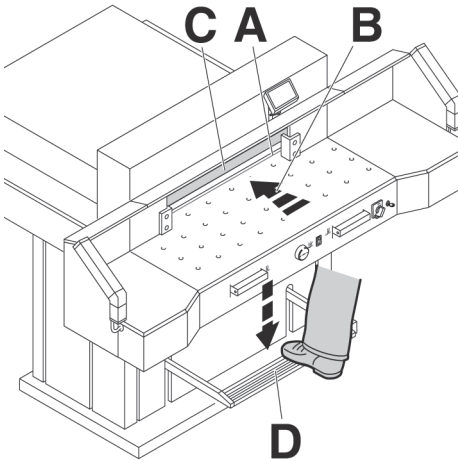

Optical cutting line indicator:

Optical cutting red line (A), indicates the position of the cut. Blade cuts on the front edge (B) of the light beam.

Mechanical cutting line indicator:

The clamp (C) can be used as cutting line indicator for cutting. Pre-clamping can be performed using the foot pedal (D).

Only use the optical cutting line indicator and mechanical cutting line indicator when no exact cut is required.

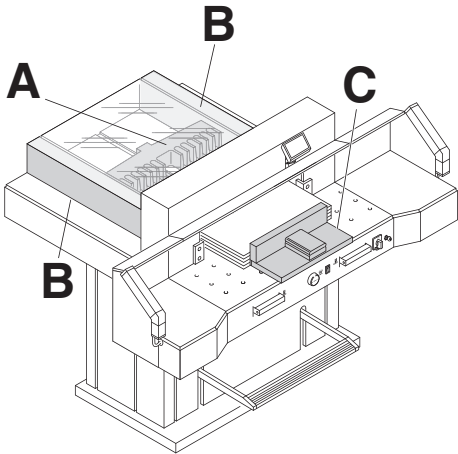

Position the paper on the backgauge (A) and side lays left or right (B).

To move paper stacks, please use the paper knock-up block (C) provided.

(Run backgauge to the front for turning the paper stack).

Operation

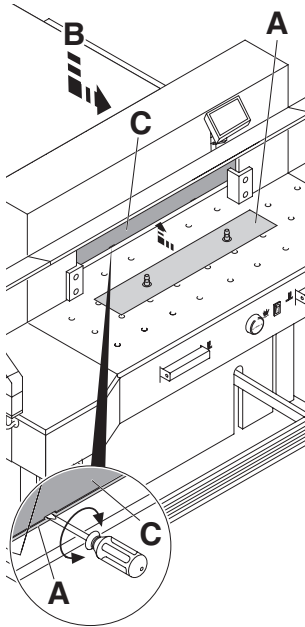

False clamp plate:

A clamp plate (A) is fitted to the machine to prevent pressure marks on sensitive material.

To dismantle:

- Remove the clamp plate (A) by turning the screwdriver (found in tool box) in the space between the clamp and clamp plate.
- Store the clamp plate in the provided holder (B).

→ The remaining cut, without false clamp, is 20 mm

⚠ Warning!

Make sure the false clamp is in the provided holder otherwise the measurement from 20 mm - 90 mm cannot be cut.

To mount:

- The clamp plate (A) is inserted to the top into the clamp (C).

→ The remaining cut, with false clamp, is 90 mm

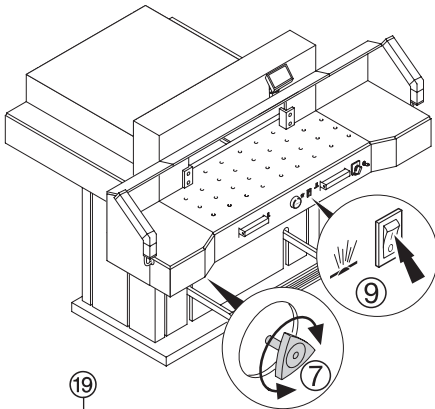

Airtable:

It is easier to position large stacks of paper when the airtable ⑨ is switched on.



Setting clamping pressure:

The clamp pressure can be adjusted using the adjustment knob ⑦. The clamping pressure can be read on the light panel ⑱.



CLAMPING PRESSURE		1500	72.00 CM				
A2	A3	Memory 1	CLEAR	7	8	9	+

Operation

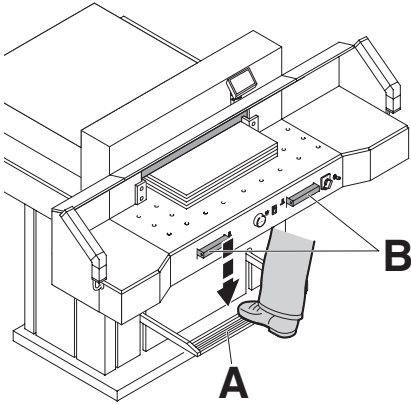

The clamp moves automatically when cutting is activated.
The paper can be pressed in advance, with the foot pedal.
Cutting is activated by pressing both actuators (B) on the front table.

Symbols for cutting activation:

Cutting sequence with automatic clamping.

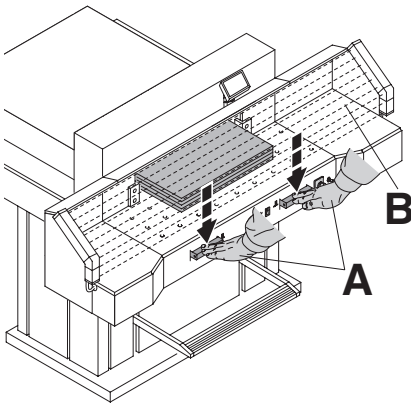

Cutting activation:

Press both actuators of the two-handed control system (A) simultaneously and keep them pressed until the paper is completely cut. The safety area (B) must be free.

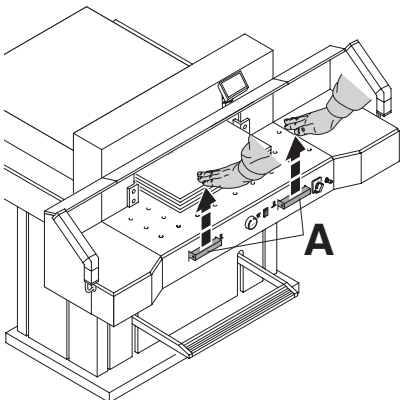

To interrupt or stop cutting:

To interrupt or stop cutting, release both actuators (A) of the two-hand control.

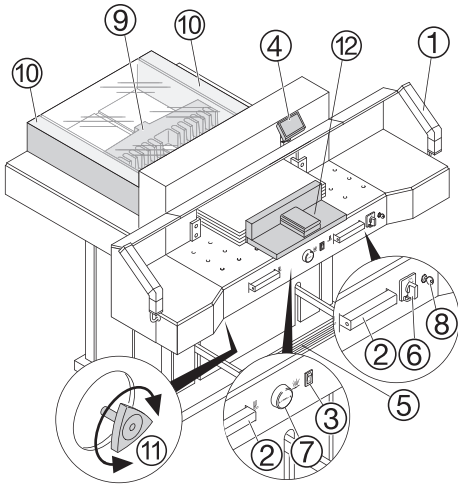

Operating elements

- ① - Safety light beam
- ② - Safety two-handed control system clamping and cutting
- ③ - Air table On-Off
- ④ - Backgauge control
- ⑤ - Foot pedal
- ⑥ - Main switch
- ⑦ - Hand-wheel for backgauge setting
- ⑧ - Key switch
- ⑨ - Backgauge
- ⑩ - Side lay left and right
- ⑪ - Clamp pressure adjustment
- ⑫ - Paper knock-up block

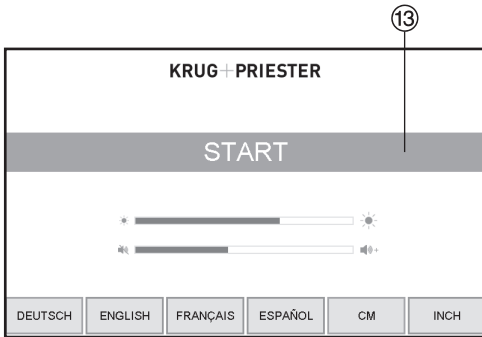

Start machine

- Main switch ⑥ to position "I". Start screen appears. The following functions are changeable: Brightness, CM/INCH, Touchtone volume, Language, Display / status photocell ⑳ green - red, Clamping pressure ㉑
 - Press START ⑬ → backgauge ⑨ moves to the rear and searches for the reference position, wait until a measurement is shown in the display ④
7260 = 72.00 cm, 28.346 inches
 - The DIN and free programmable measurements are recallable with the respective buttons ㉒.
- Memory 1: A2, A3, A4, A5,
Memory 2: A6, A7, B3, B4
Memory 3:
Memory 4:
- and in inch
Memory 1: 4 1/4", 5 1/2", 7", 8 1/2"
Memory 2: 11", 12", 14", 17"
Memory 3:
Memory 4:

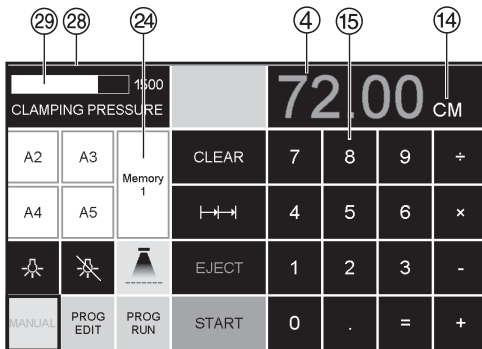

Operation

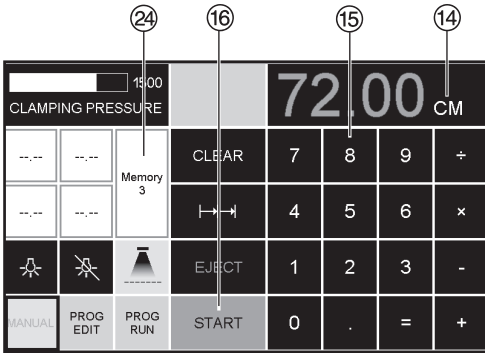

- In memory 3 + 4 (mm and inch) no measurements are saved. Until a first input of data the following will be shown in the corresponding fields: . **The measurements entered remain stored. They cannot be deleted but overwritten.**

How to program Memory 3 and 4

Press the memory button to enter the memory platform (3 or 4). Enter the required measurements or overwrite them. Press the button and keep it pressed until an acoustic signal sounds, the measurements have been saved now.

Warning!

Before storing or cutting a measurement please check if the correct measurement scale (cm or inch) see above is stored. (7260 = 72.00 cm, 28.346 inches) Is shown on the screen see .

After 30 minutes the machine () switches to energy-saving mode. The machine is reactivated by touching the keypad area .

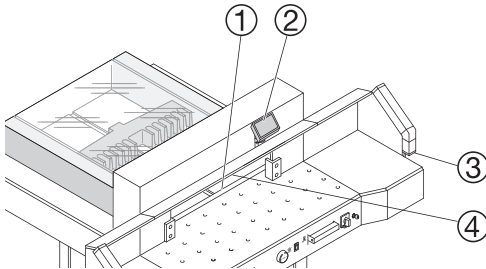

Bright LEDs illuminate the working area (). The LED button () has 3 switching steps

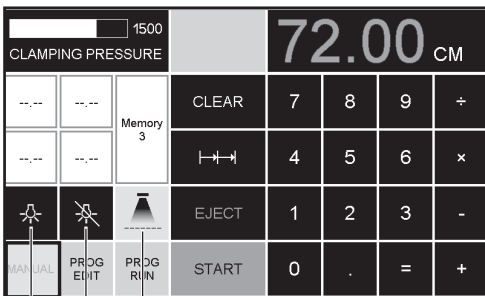

Press 1 x → brightness 3
 Press 2 x → brightness 2
 Press 3 x → brightness 1

Light OFF → .

Optical cutting line indicator → (ON/OFF) .

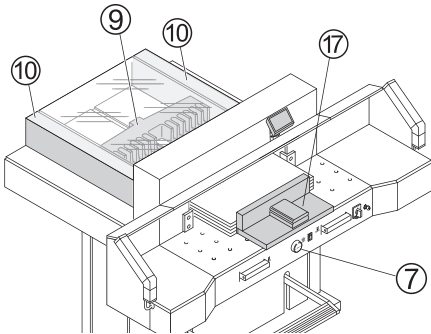

Cutting activation

⚠ Warning!

- Run backgauge to the front for turning the paper stack
- Do not interrupt the upward movement of the blade by performing switching procedures
- Wait until the display is green before activating a cut
- Blade must always be at the top and be covered by the clamp. Do not touch the blade.

⚠ Risk of injury!

Cutting to specified dimensions

- Press **MANUAL**
- Enter dimension on the numerical key pad ⑮ → Measurement is shown in red (If a wrong dimension is entered this can be corrected by pressing the **CLEAR** button)
- Press **START** ⑯ → dimension is approached, → Measurement is shown in green
- Insert paper and move by means of the stacking angle ⑰ to the backgauge ⑨ and side lay on the left ⑩
- Release the cut.

Cut according to markings

- Press **MANUAL**
- Adjust the backgauge with the hand-wheel ⑦ to the back
- Insert paper and move by means of the stacking angle ⑰ to the backgauge ⑨ and side lay on the left ⑩
- Turn the hand-wheel ⑦ to the right until the marking on the paper to be cut is below the cutting line indicator
- The further the hand-wheel ⑦ is turned to the right, the quicker the backgauge moves. If the hand-wheel is turned to the left the backgauge will return quicker.

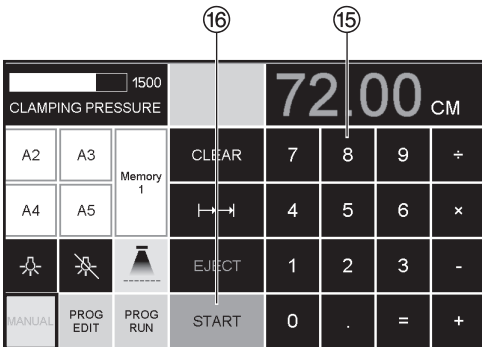

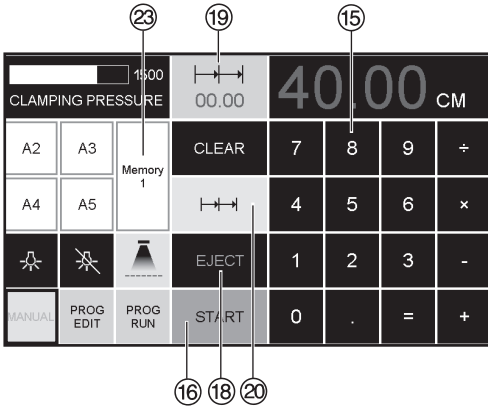

Eject function

If EJECT **18** is pressed instead of START **16**, after inserting the measurement **15**, the backgauge will advance forwards so that paper can be removed. Finally the backgauge moves to the last setting.

Multiple cut

- Enter the start dimension on the display **15**
- Advance to the measurement with the START **16**
- Push the paper to the backgauge
- Press multiple cut **20**
- Multiple cut sign appears top left together with the value **00.00** **19**
- Enter multiple cut measurement (appears in red letters)
- Press START → the backgauge advances by the multiple cut size
- This is repeated everytime a cut is activated.

Exiting program-mode

- Press multiple cut **20** (yellow). Multiple cut sign and value are deleted.

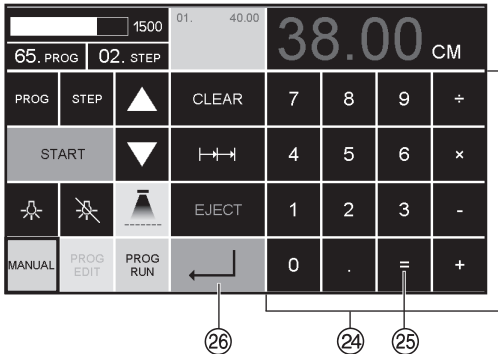

Calculator function **24**

- Calculate the desired measurement, e.g. $40 - 2 = 38$ **25** → ↓ **26** and the backgauge advances immediately to 38.

Operation

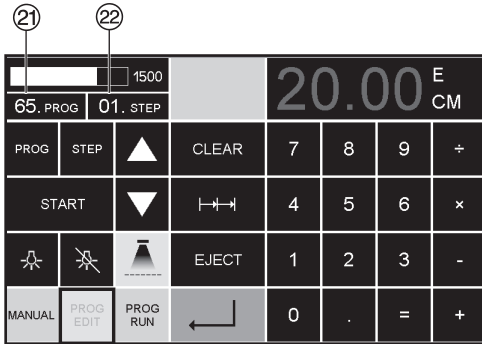

Programming

This control system enables you to store 99 programs with 99 programmable steps. One step represents one measurement. After entering the program numbers you are able to change between several program steps with the button and . First figure on display ②① = program number. Second figure on display ②② = program step.

Each program step corresponds to one dimension. The indicated program step can be overwritten at any time. These programs remain stored when the machine is off.

Entering a program

- Press **PROG EDIT** → "Load program no." appears
- Enter program number 01 ... 99, with (Top number ②① on display = program number)
- If measurement is shown on the display the program is reserved, select another program
- Program step "01 Step" 00.00 ②② appears. (Second figure on display ②② = program step.)
- Enter dimension, or move the backgauge to the desired measurement with the hand-wheel ⑦
- Store the measurement , next program step appears.
- Enter the next measurement and with Enter store the measurement etc.
- Should the entered program be required immediately → press **PROG RUN**
- Press Enter
- Press START
- Escape the program mode press **MANUAL**

Cancel a program

- Press **PROG EDIT**
- Scroll with PROG until "Delete program no." appears
- Enter Program number
- Press Enter
- Press Enter

Operation

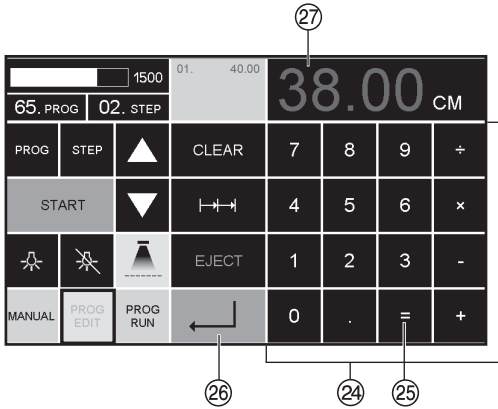

Calculator function ②④ in programming

- Press **PROG EDIT** ②④
- Enter program number
- Enter the 1st program step e.g. start-up measurement 40 cm
- Store the measurement with enter ↵ ②⑥
- Calculate the desired measurement e.g. $40 - 2 = 38$ ②⑤ → ↵ ②⑥, the calculated measurement 38 ②⑦ flashes.
- Pressing the Enter-key ↵ ②⑥ again, the calculated measurement is saved in the corresponding step.

1500		02. 25.00	29.98 CM			
22. PROG	01. STEP	01. 30.00				
PROG	▲	CLEAR	7	8	9	+
STEP	▼	MODIFY	4	5	6	x
☀	☀	☀	EJECT	1	2	-
MANUAL	PROG EDIT	PROG RUN	START	0	.	= +

23

Adapting a program when the printer's imprint deviates

- Press **PROG RUN** → "Load program no." appears
- Enter program number 01 ... 99, and with 2 x Enter ↵ proceed to Step 1
- Correct the cutting position of the backgauge with the hand-wheel
- **MODIFY** 23 appears on the screen and the measurement flashes
- To store press **MODIFY**
- Release a cut and turn the paper
- If the printer's imprint deviates it can be corrected during the first two cuts via the hand-wheel – see above
- Correction is only possible during the first two cuts
- After leaving the **PROG RUN** mode the original data is stored again.

Delete a step

- Press **PROG EDIT**
- Enter program number, confirm with Enter ↵
- Select program step with the arrow keys ▲ and ▼
- Scroll with **STEP** until "Delete step no." appears, Press 2 x Enter ↵.

Insert a step

- Press **PROG EDIT**
- Select a program, confirm with Enter ↵
- Scroll with **STEP** until "Insert step no." appears
- Enter insert position e.g. 02
- Confirm with Enter ↵
- Enter a measurement
- Store the measurement with ↵
- The cutting position can be shown on the screen with the arrow keys ▲ and ▼.

Changing a program step

- Press **PROG EDIT**
- Select a program, confirm with Enter ↵
- Scroll with **STEP** until "Load step no." appears
- Enter step position e.g. 03
- Confirm with Enter ↵
- Enter a new measurement, Store the measurement with ↵.

Operation

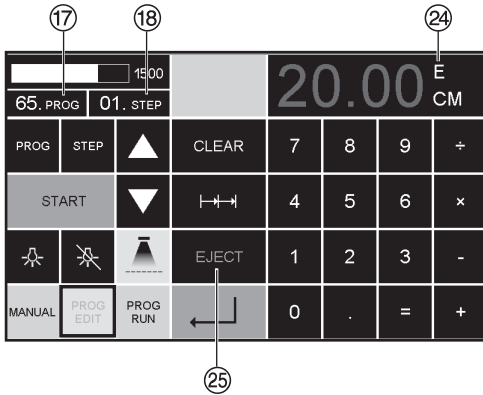

Eject function program

- If a short measurement e.g. 30 cm and then a long measurement e.g. 40 cm is cut at the start of a program then it is wise to insert an EJECT ²⁴ after the first cut so that the paper is pushed to the front.
- The EJECT function can be added each time a measurement is entered and ejects before advancing to the next measurement. When the eject function is programmed an "E" ²⁴ appears top right in the display.
- Inserting an Eject function subsequently in the program. Select a program and advance to the step to be changed with the arrow keys [▲] and [▼]. Enter the new measurement and before activating the enter button [↵] press EJECT ²⁵.

Example of a program eject function

- Press **PROG EDIT**
- Enter program number e.g. 08
- Press Enter [↵]
- 1. Enter program Step e.g. 30 cm
- Press Enter [↵]
- 2. Enter program Step e.g. 40 cm
- Press EJECT and with Enter [↵] store the dimension.

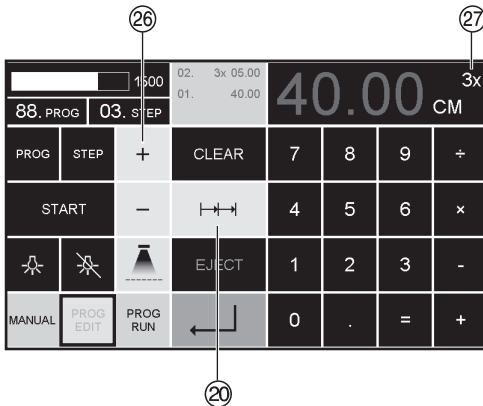

How the example works

- Press **PROG RUN**
- Enter program number 08
- Press Enter [↵]
- Press START, Measurement is approached
- Insert paper
- Release cut 1
- Eject (Ejection is completed, turn the paper)
- The backgauge moves to program step 2
- Release cut 2

Multiple cut program

- Press **PROG EDIT**
- Enter program number
- Enter the 1. program step e.g. start-up measurement 40 cm
- Store the measurement with Enter [↵]
- Press the multiple cut symbol ^{↔↔↔} ²⁶
- Enter the number of cuts ²⁶ with the + button ²⁷ (max. 15 cuts) followed by the multiple cut size (cutting width).
- Store with Enter [↵].

Blade and cutting stick replacement

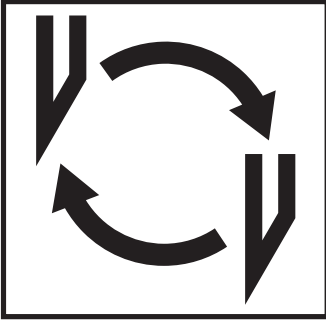

If the cutting quality decreases:

- Check the cutting depth (see page 32).
- Check the cutting stick (see page 28).
- Replace or grind the blade (see page 24 - 32).

The blade cannot be ground if the blade height is less than 8,3 cm / 3,29 inches. A new blade must be used.

The blade may only be ground by a qualified supplier or from the manufacturer Krug & Priester, D-72336 Balingen.

⚠ Danger! Risk of injury!

The blade is extremely sharp. Do not extract or transport the blade without protection. Changing the blade may only be performed by trained staff.

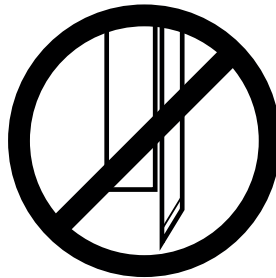

Blade and cutting stick replacement

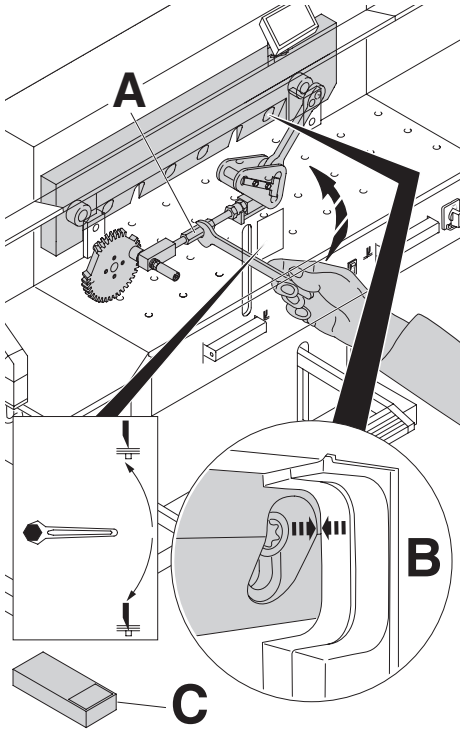

Turn the blade depth adjustment (A) towards the top until the blade screw recess corresponds with the frame recess (B). (Spanner found in tool set (C)).

Remove spanner

⚠ Danger! Risk of injury

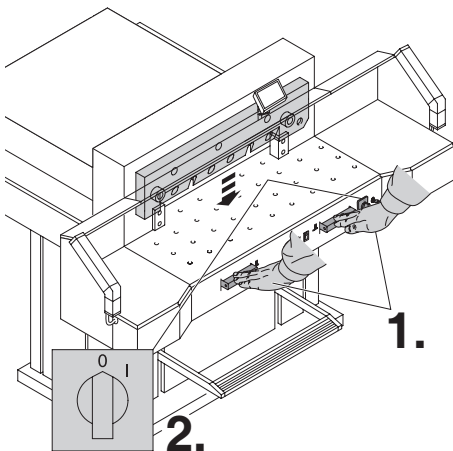

Lower the blade by pressing both cutting buttons (1.). Keep one button pressed and turn off the main switch (2.).

Blade and cutting stick replacement

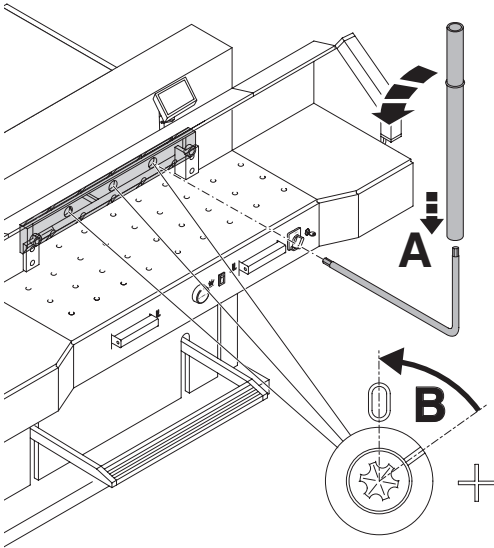

The 3 eccentrics are now exposed and should be turned counter clockwise to position "0" with the special wrench and attachable extension pipe (A) (in the tool set). The slot must correspond to position "0" (B).

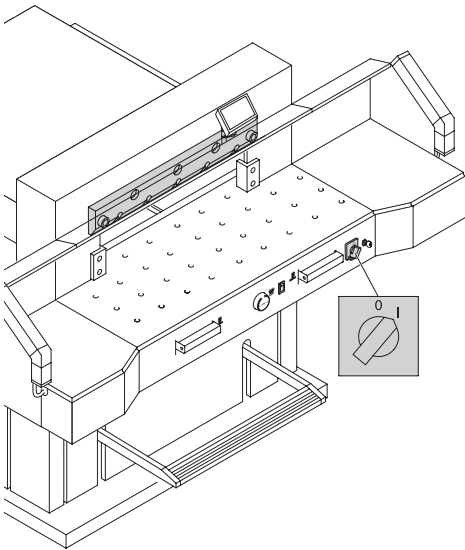

Remove the special wrench and turn on the main switch until the blade returns to the home position.

Blade and cutting stick replacement

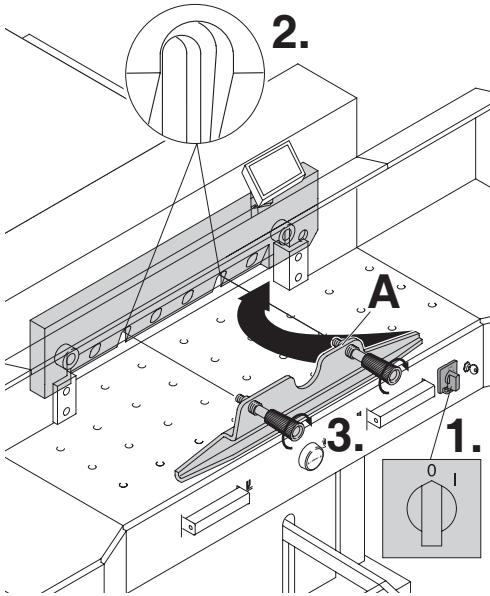

Position the main switch to "0" (1.)
Remove the 2 blade screws on the elongated holes (2.). Then put the blade changing tool (A) into place and fasten it to the blade (3.).

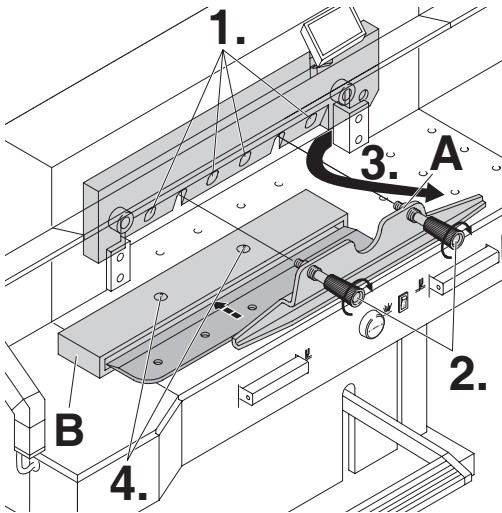

Remove 4 blade screws (1.)
Loosen the grips (2.) of the blade changing tool (A) lightly and allow the blade to be taken downwards out of the machine (3.). Place the blade into the blade carrier (B) and screw it into place (4.).

Blade and cutting stick replacement

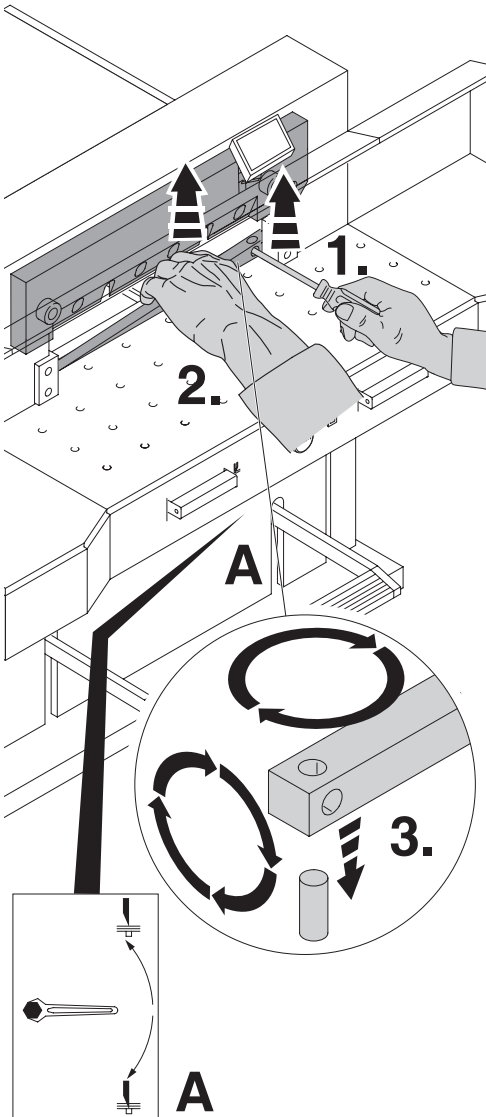

Take out the cutting stick with a small screwdriver. If needed the cutting stick can be turned or exchanged. (The cutting stick can be used eight times).

Replacing the cutting stick (not the blade)

- Turn the blade depth adjustment (**A**) towards the top until the blade screw recess corresponds with the frame recess. See page 25. (Otherwise the first cut will be too deep).
 - **Remove spanner**
 - Remove the cutting stick according to top picture.
 - Turn the cutting stick (the non-used side must be near to the blade) and plug it into the left holding bolt.
- ⚠ **Danger!** Risk of injury!

Cutting test after replacing the cutting stick (not the blade)

- Insert the paper and release the cut.
- If the last sheet of paper is not cut along the entire length turn the blade depth adjusting screw (**A**) 1/12 downwards using a spanner.
- If the last sheet is still not completely cut repeat this process until the last sheet is cut along the entire length.

Blade and cutting stick replacement

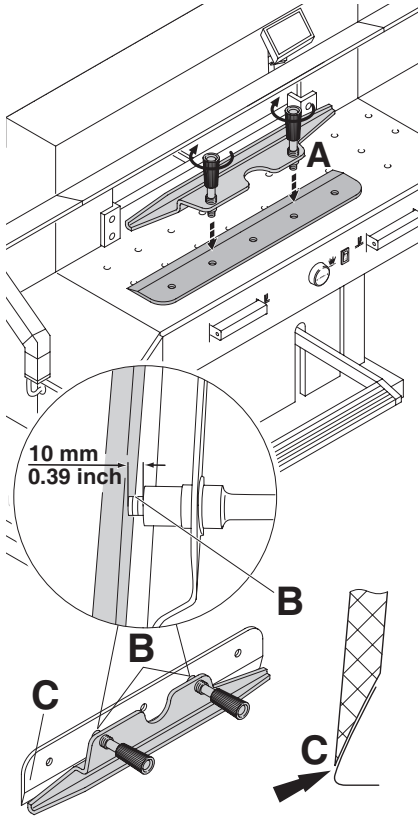

Take the exchange blade carefully out of the blade box and screw it to the blade changing tool (A)

- Make sure there is a space of 10 mm or 0.39 inches! (B).
- Blade must be covered! (C).

⚠ **Danger!** Risk of injury!

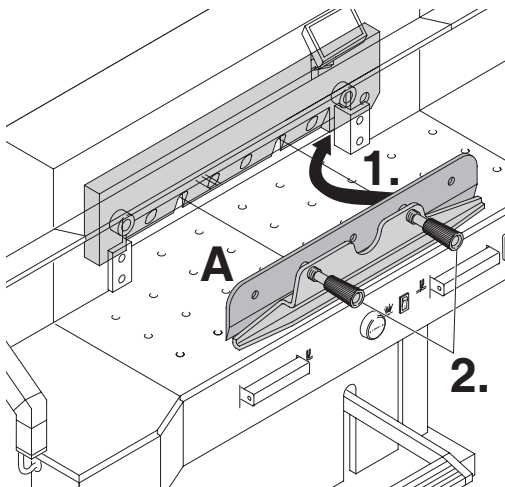
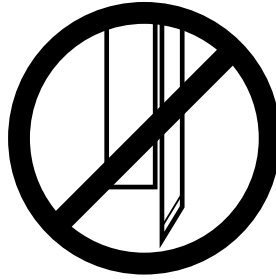

Place the blade to be exchanged with the blade changing tool (A) mounted (1.), into the blade carrier and push it up to the top and screw it into place with the grips (2.).

Blade and cutting stick replacement

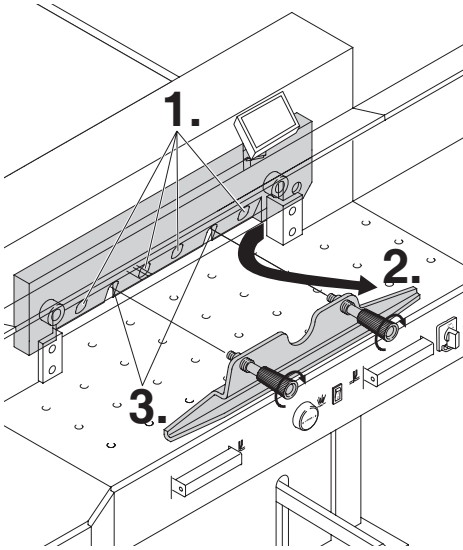

Lightly tighten 4 of the 6 blade screws with washers (1.). Remove the blade changing tool (A) (2.). Lightly tighten the remaining blade screws with washers (3.).

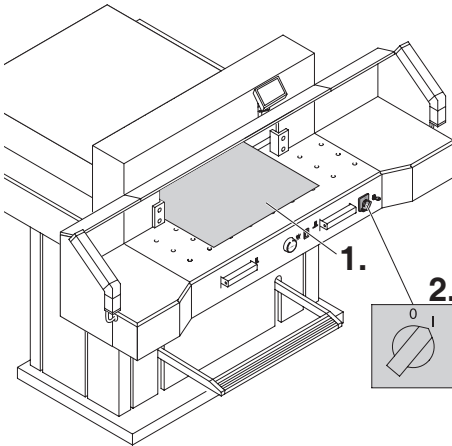

Remove all tools and distribute paper along the entire cutting length (1.). Turn main switch to position "I" (2.).

Blade and cutting stick replacement

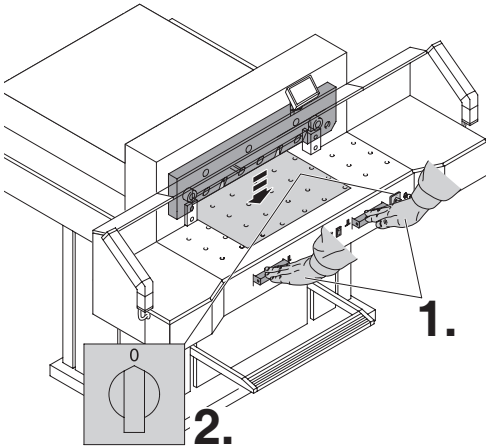

Lower the blade by pressing both cutting buttons (1.). Keep one button pressed and turn off the main switch (2.).

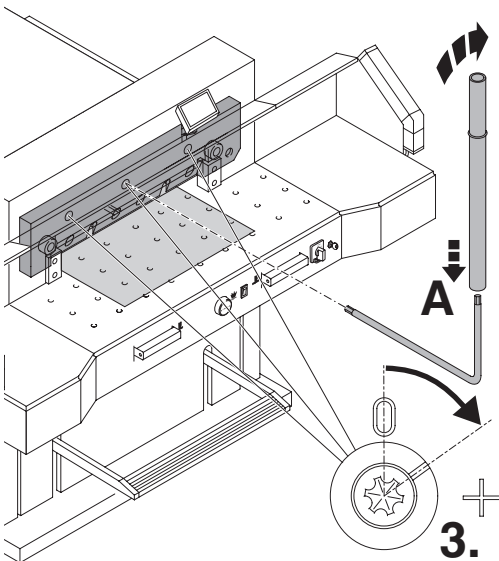

With the special wrench (A) the 3 eccentrics should be screwed down until the paper is cut along the entire length of the blade (3.) (The blade must remain parallel, not too deep into cutting stick).

Blade and cutting stick replacement

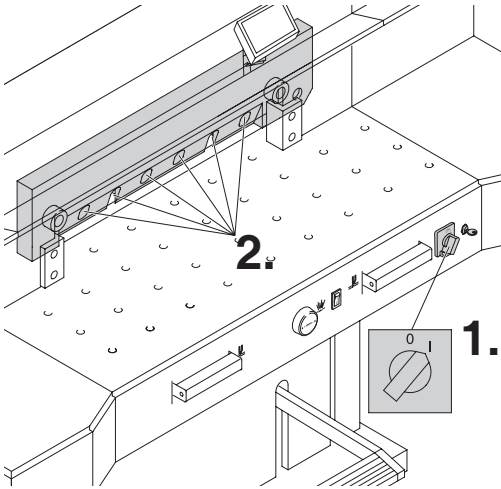

Turn main switch to position "I" (1.). Blade will return to upper position. Tighten 6 blade screws (2.) firmly.

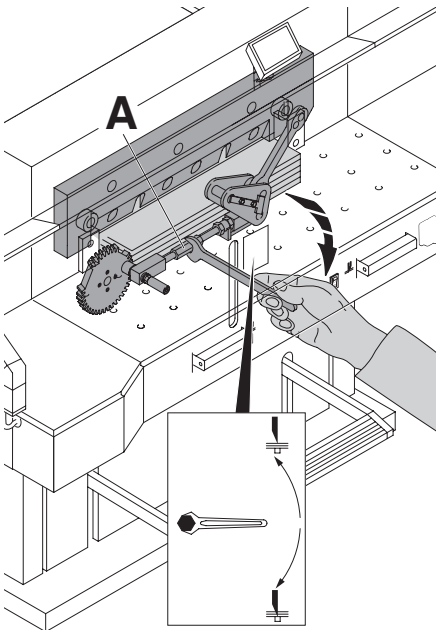

Paper cutting test. If the last sheet or several sheets are not completely cut, gradually turn the blade depth adjustment (A) 1/12 downwards until all the paper is completely cut. Do not set too low as blade will become blunt sooner.

Maintenance and cleaning

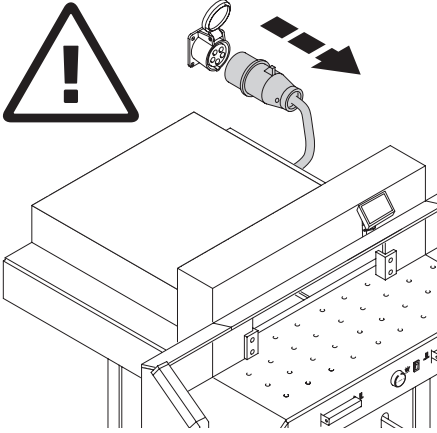

⚠ Danger!

- Maintenance work may only be performed by trained staff.
- Disconnect the mains before starting any service work or before removing the cover.

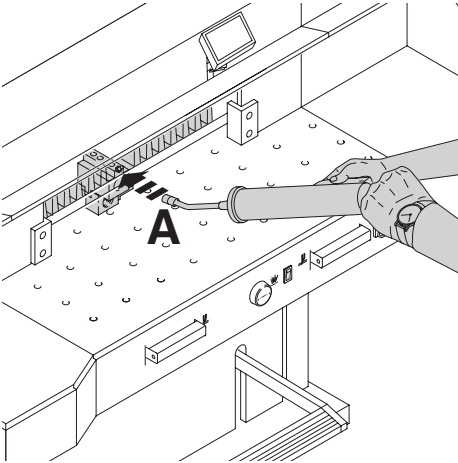

Grease the backgauge (A) control weekly with a grease gun. Advance the backgauge as far as possible to the front (use special grease for cutting machines).

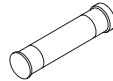

Grease cartridge
• No. 9800 933

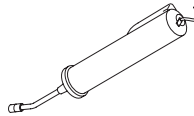

Grease gun
• No. 9004 683

Maintenance and cleaning

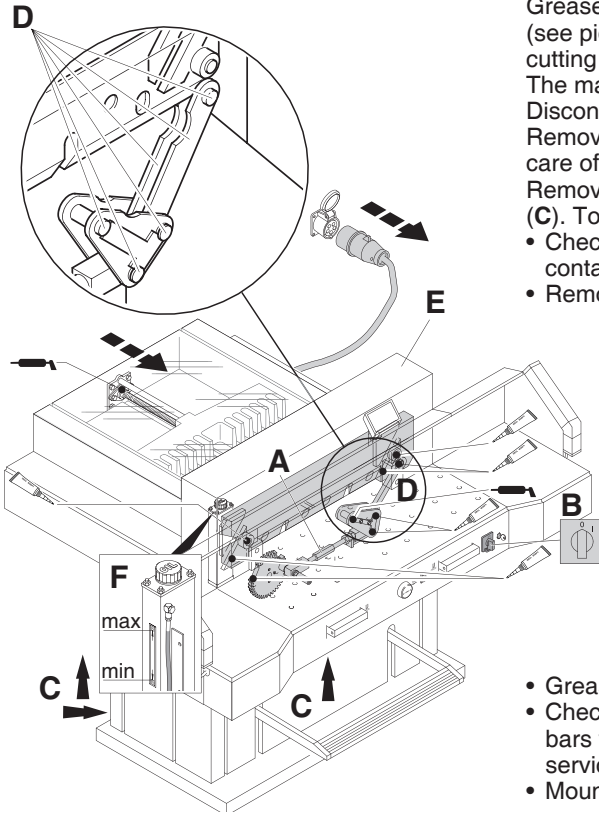

Grease the remaining parts twice a year (see picture) use special grease for cutting machines.

The main switch must be on "0" (B).

Disconnect from the mains.

Remove the front upper housing (E) → taking care of the cable.

Remove lower panel and rear wooden panel (C). Tools in tool set.

- Check oil (F). If oil is below minimum contact your dealer.
- Remove any paper.



No. 9000 625

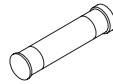

No. 9800 933



No. 9001 828

- Grease the machine.
- Check the 4 joining bolts and 2 pushing bars for wear (D). If necessary inform your service personnel.
- Mount the machine.

With more than 5 hours of use per day, the service must be performed more often.



= Greasing points on the machine.

Maintenance and cleaning

Next Maintenance

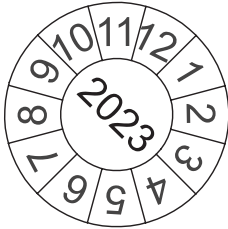

Krug & Priester GmbH & Co. KG
72336 Balingen - Germany

Parts & Service HOTLINE

Germany: +49 7433 2690
France: +33 3 8820 5435
North America: +1 843 552 2700
All other countries: Please contact
your local distributor
www.krug-priester.com

Annual inspection

To maintain the operational safety and to prevent premature wear, we recommend an annual inspection and maintenance of the machine by a qualified service technician.

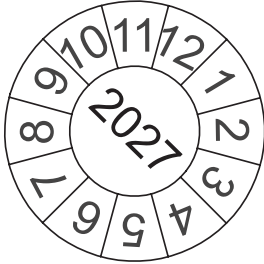

Safety test

The safety regulations are according to the regulations of the country where the cutting machine is operated. The manufacturer recommends a safety check is made every 5 years by an authorised service team.

Possible malfunctions



Machine does not function!

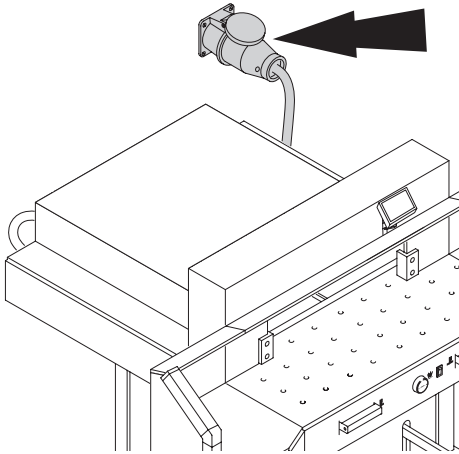

Is the machine plugged in?

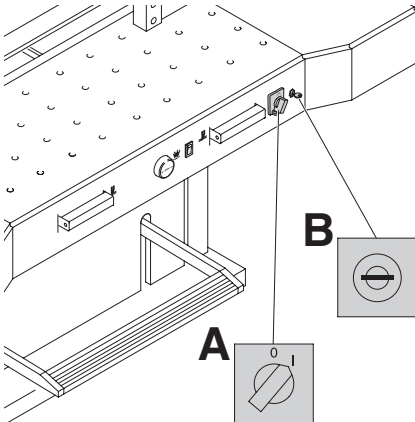

Main switch to position "I"? (A)
Control system activated? (B)
(Turn key to the right)
Check the units fuse and the on-site circuit
breaker!
Release a cut see page 15.

Possible malfunctions

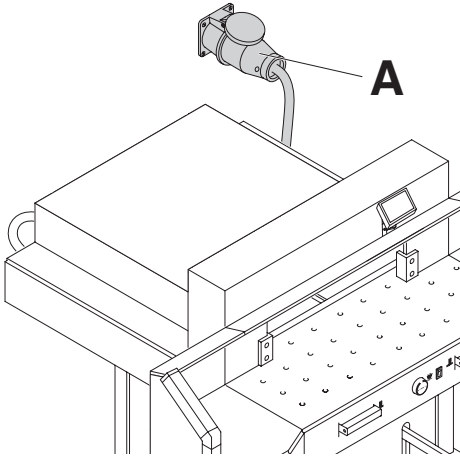

The machine does not function after being moved to another position.

If the machine still does not function then the rotation must be reversed. The machine is wired according to the IEC standards. We recommend that alterations to the rotary direction be made in the socket. It is also possible to make alterations in the plug by exchanging "L1" and "L2".

⚠ Danger!

Incorrect exchanging of the connections will endanger the operator.

This work must be carried out by an electrician.

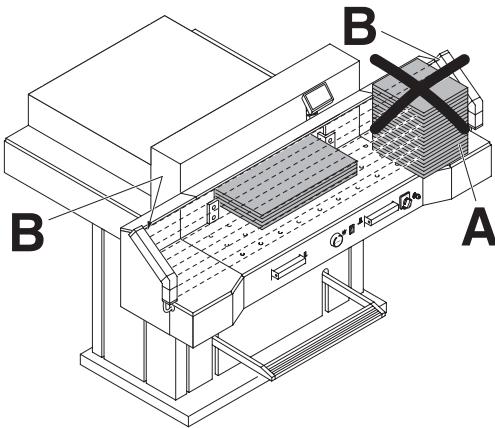

Cut cannot be activated.

- **Safety light beam is interrupted /dirty.**

Remove all items obstructing the safety area (A) and clean the glass from the sender (B) and receiver (B).

- **Measurement has not been reached correctly.**

Push the  button again.

- **Measurement below 9 cm.**

The false clamp plate must not be mounted. Remove the false clamp plate and store it in the **provided holder** (see page 14).

Possible malfunctions

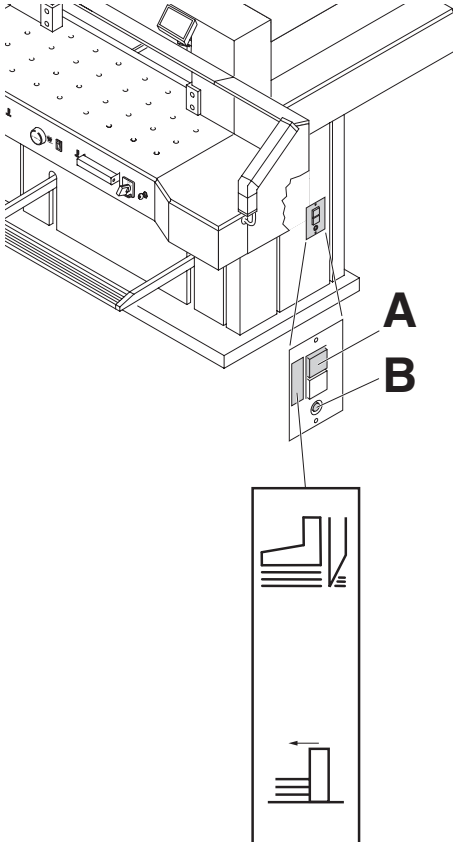

Machine turns off:

- **Machine overloaded.**
Safety button (A) ejects.
Reset the safety button (A).
- **Machine blocked.**
- **Blade is blunt.**
Eliminate the cause, and push the safety button (A).
- **Backgauge blocked**
Safety button (B) ejects.
Eliminate the cause, and push the safety button (B).

Safety button for:

A = Blade drive

B = Backgauge drive

Possible malfunctions

A

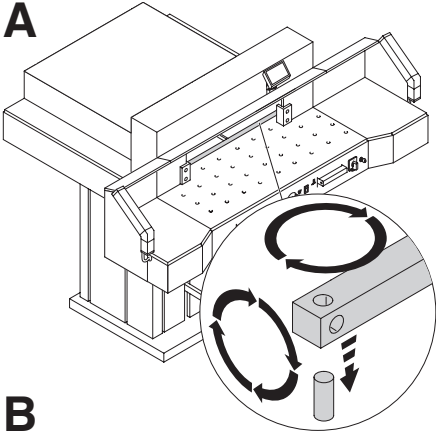

Does not cut through the last sheet:

- Turn or turn around the cutting stick (A), readjust the blade by means of blade depth adjustment (B) (see page 32).

B

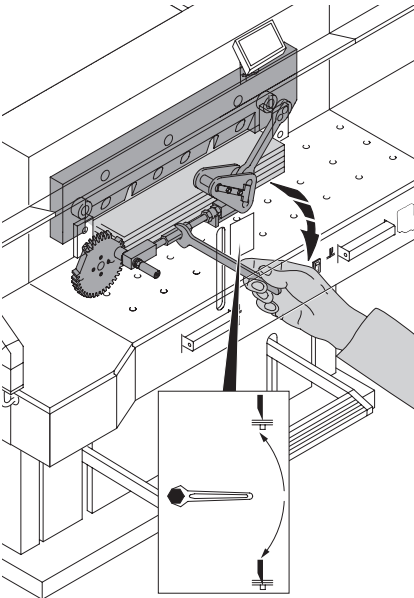

Poor cutting quality or blade stays in the paper stack.

- Change the blade (C) (see pages 24 - 32).

C

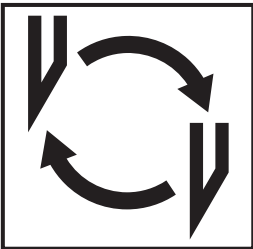

Possible malfunctions

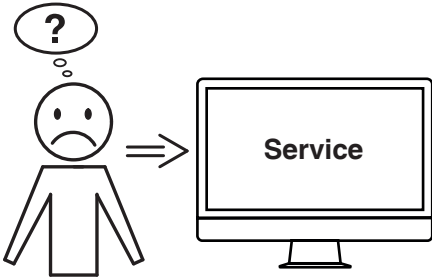

Motor runs but blade does not move downwards.

- Security brake has been activated!
Inform the Service Team!
- www.krug-priester.de → "Service"
service@krug-priester.com

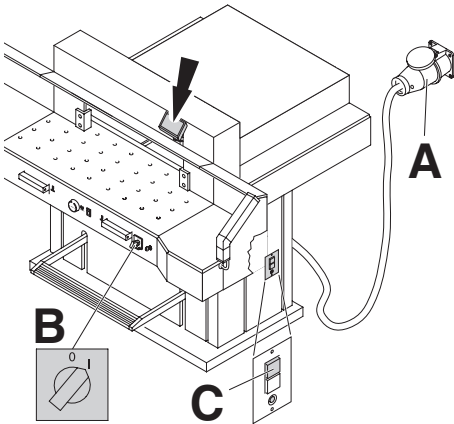

Display illumination off

- Is the machine plugged in? (A)
- Is the main switch on position "I"? (B)
- Push in the green safety button! (C)
- Check the units fuse and the on-site circuit breaker!

Possible malfunctions

No clamp pressure.

- Hydraulic oil needs refilling (F).
- Contact your dealer.

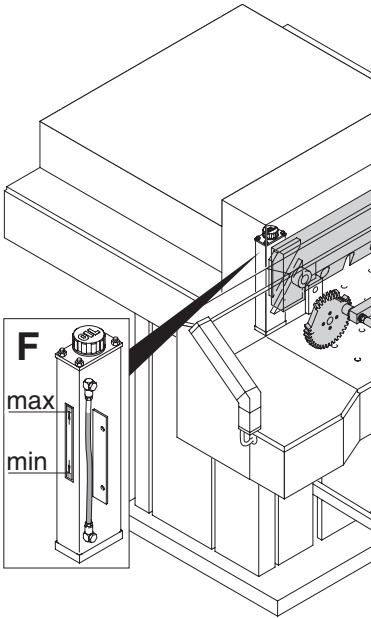

Trouble shooting-light beam

Cut cannot be activated:

- Remove all items obstructing the safety area (A)
- (B) Green = o.k. / ready for operation
Red = light beam is interrupted or error

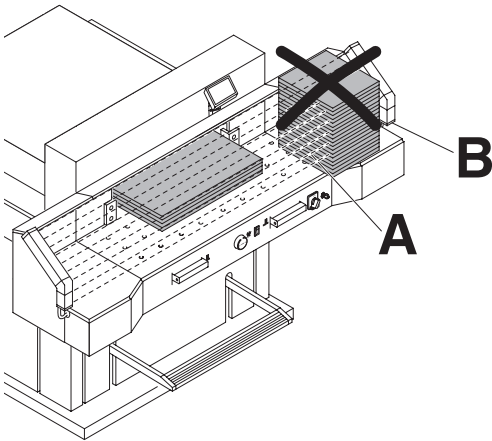

Possible malfunctions

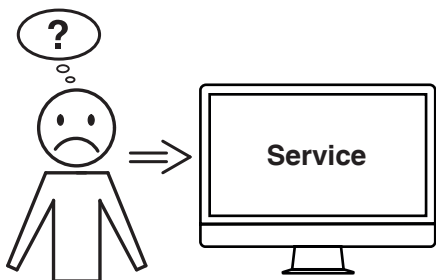

Did none of the specified solutions help you with your problem?

- Contact: Service
- www.krug-priester.com
- service@krug-priester.com

Accessories

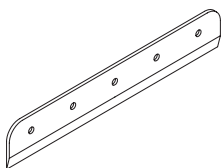

HSS - Blade
• No. 9000 141

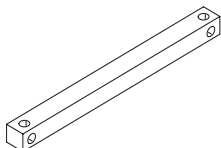

Cutting stick (6 pieces)
• No. 9000 039

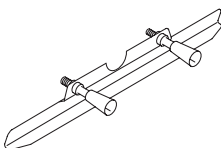

Blade changing tool ¹
• No. 9000 514



Grease tube ¹
• No. 9000 625

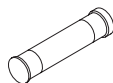

Grease cartridge
• No. 9800 933



Brush
• No. 9001 828

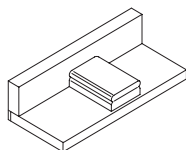

Paper knock-up block ¹
• No. 9000 521

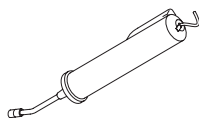

Grease gun
• No. 9004 683

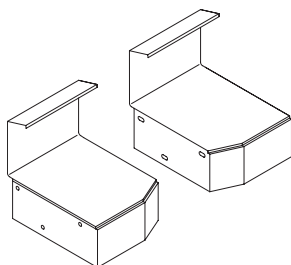

Side tables left and right
• No. 9000 551

¹ Included in delivery

Technical data

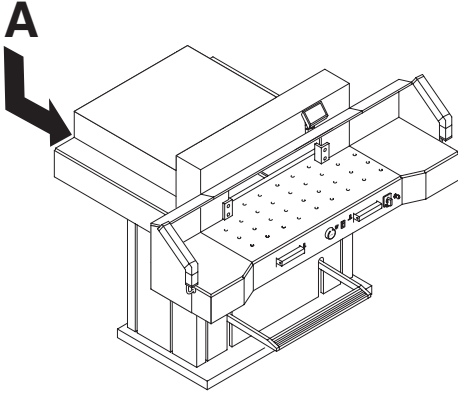

Technical data:

- Power supply:
400 V, 3P+N+PE
220 V, 3P+PE
- Cutting length: 720 mm
- Cutting height: 80 mm
- Table depth: 720 mm
- Sound level EN 13023: 72 dB (A)
- Minimum space requirement
(width x depth x height)
1305/2100¹mm x 1540/1600¹mm x 1335 mm
- Leakage current < 3,5mA
- Power cord gauge:
400 V: 5 x 1,5 mm², 16 A
220 V: 4 x AWG 14, 20 A
- Clamping pressure: min. 250 daN,
max 2000 daN
- Weight: 588 kg, 628 kg¹
- Capacity of hydraulic oil: 1,5 l
HLPD, viscosity 46 mm²/ sec. to DIN 51562.
Used oil must be disposed of at the
authorised place.

¹ with side tables

The exact technical specifications can be found on the technical specifications sticker (A) on the machine. A wiring diagram is found in the electrical switch box.

To claim under guarantee, the machine must still carry its original identification label.

Safety light beam

- Total reaction time: 120 ms
- Resolution 14 mm/minimum distance: 250 mm
- Resolution 24 mm/minimum distance: 320 mm
- Resolution 39 mm/minimum distance: 440 mm

Ambient operating temperature 10 °C - 60 °C
Air humidity (not condensating) 15 % - 95 %

Technical data



The company Krug + Priester has the following certifications:

- Quality management system according to DIN EN ISO 9001:2015
- Environmental management system according to DIN EN ISO 14001:2015
- Energy management system according to DIN EN ISO 50001:2018

Technical data



I.T.E. Listed 802 D



This machine is approved by independent safety laboratories and is in compliance with the EC-regulations 2006/42/EG and 2014/30/EG.

Sound level information:

The sound level is 72 db (A) as defined by EN 13023.

Subject to alteration without notice.

EC-declaration of conformity

EC-declaration of conformity

- Herewith we declare that

7260	GS- IDENT. Nr. 11072101	UL- IDENT. Nr. 10072101
------	----------------------------	----------------------------

- complies with the following provisions applying to it

2006/42/EG:

EC Machinery directive

2014/30/EG:

EMV Electromagnetic compatibility directive

2011/65/EU, 2015/863/EU

RoHS directive

- Applied harmonised standards in particular

**EN 60204-1; EN 1010-1; EN 1010-3; EN 55014-1; EN 55014-2;
EN 61000-3-2; EN 61000-3-3; EN ISO 12100;
EN ISO 13857; EN ISO 11204; EN 13023; EN ISO 13849-1;
BS EN 60204-1; BS EN 1010-1; BS EN 1010-3; BS EN 55014-1; BS EN 55014-2;
BS EN 61000-3-2; BS EN 61000-3-3; BS EN ISO 12100;
BS EN ISO 13857; BS EN ISO 11204; BS EN 13023; BS EN ISO 13849-1**

14.02.2022

Date

Authorized representative for technical documentation



Krug & Priester GmbH & Co. KG
Simon-Schweitzer-Str. 34
D-72336 Balingen (Germany)

- Managing Director -

Document Shredders



Trimmers and Guillotines

